

# Montage® Antibody Purification Kit and Spin Columns with PROSEP®-G Media

## User Guide

P36491, Rev. D, 07/08

### Introduction

Affinity purification of monoclonal and polyclonal antibodies most commonly uses Protein A and Protein G chromatography. The Montage Antibody Purification Kit with PROSEP-G media is designed for simple and rapid antibody purification from serum, ascites, and tissue culture supernatants.

The Montage Antibody Purification Kit contains pre-packed Protein G media plugs and spin columns, along with the buffers and filtration devices necessary for pre-clarification of the source material and concentration of the purified antibody. Spin columns with PROSEP-G media are also available separately.

Antibody samples purified using Montage spin columns may be used in a wide range of laboratory procedures such as immunoprecipitation, immunofluorescence, western blotting, ELISA, and others. The antibodies can be used for radiolabeling, conjugations (e.g., fluorescein), or preparation of immuno-affinity columns.

### Advantages of Using the Montage Antibody Purification Kit with PROSEP-G Media

- Montage kits offer the researcher a total antibody purification process from the initial clarification stage to the final antibody concentration step.
- Montage kits use a spin column format designed to eliminate tedious chromatographic steps and expensive hardware normally associated with Protein G chromatography.
- PROSEP-G media has a proven track record for biopharmaceutical therapeutic antibody production.
- Minimal hold-up volume of the Protein G resin plug ensures high antibody recovery.
- The reusable spin columns are sufficient for 10 purifications each and multiple samples can be processed simultaneously.
- The beaded supports offer excellent flow properties that, combined with the tapering of the spin column, provide uniform flow paths enabling optimal use of the media bed in swinging bucket rotors.

### Contents of Montage Antibody Purification Kit with PROSEP-G Media

The Montage Antibody Purification Kit with PROSEP-G Media contains:

- PROSEP-G media plugs containing Protein G media, qty. 2
- Montage spin column devices (20 mL capacity in a swinging bucket rotor), qty. 2
- 50 mL centrifuge tubes with caps, qty. 4
- Amicon® Ultra-15 Centrifugal filter devices with 30,000 kDa NMWL Ultracel® regenerated cellulose membrane, qty. 4  
Steriflip® sterile 50 mL disposable vacuum filtration devices with MBS/PP housing and 0.22 µm Millipore Express® membrane, qty. 4
- Binding Buffer A, qty. 2 bottles, 500 mL each
- Elution Buffer B2, qty. 1 bottle, 500 mL
- Neutralization Buffer C, qty. 1 bottle, 50 mL
- Plug insertion tool
- Laminated protocol card



## Kit Components

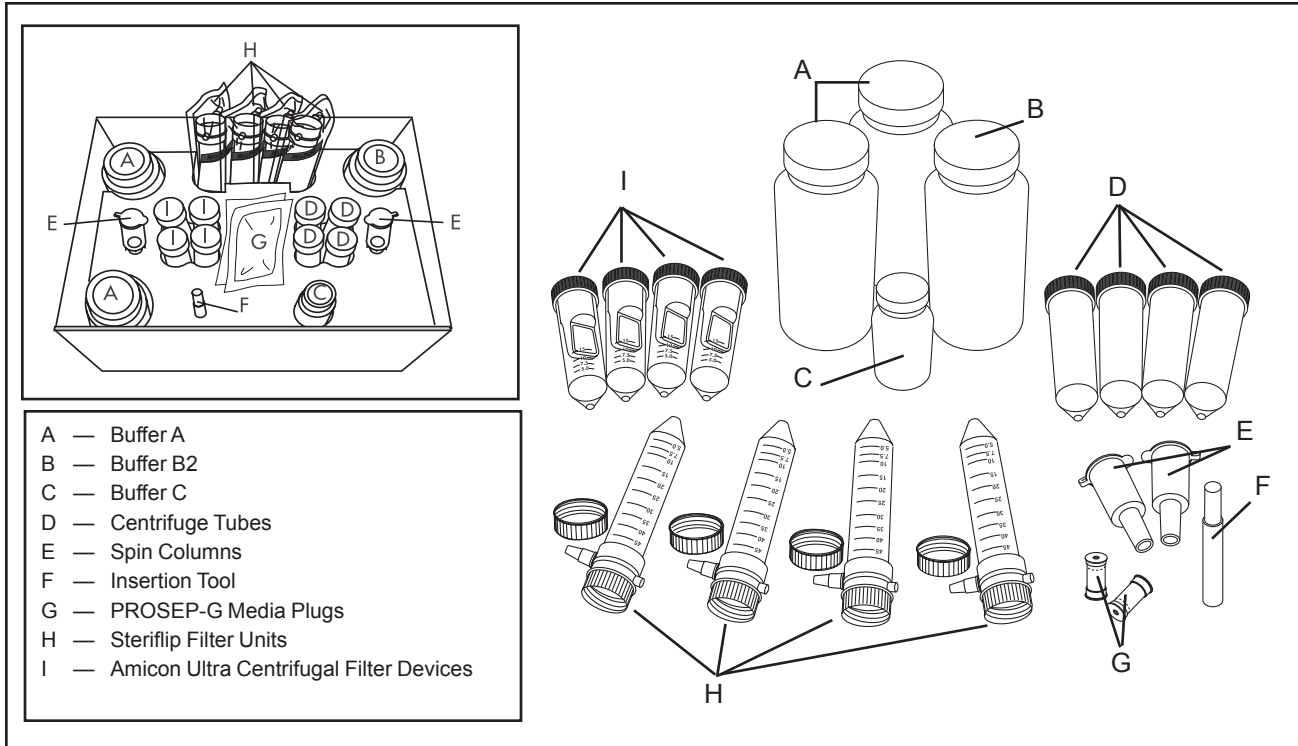

## Additional Equipment Recommended

- UV/VIS spectrophotometer
- Vacuum pressure pump or uniform vacuum source (Millipore Cat. No. WP61 115 60 or equivalent)
- Centrifuge with swinging bucket rotor that can accommodate 50 mL centrifuge tubes

NOTE: The preferred rotor is a swinging bucket rotor. For optimal performance with a fixed angle rotor, ensure that the orientation of the spin column in the rotor is the same for sample binding, washing, and elution steps.

## Storage Conditions

Remove the bag of PROSEP-G media plugs from the kit and store it at 2–8 °C. Do not freeze the media plugs or store them at room temperature. There is no need to place the rest of the kit in a refrigerator or cold room. All buffers contain 0.1% sodium azide and can be stored at room temperature. Montage spin columns are stable at 2–8 °C for up to one year from the date of receipt.

## Background Information

The following section provides information that may be helpful when preparing to purify antibodies:

- Choosing between Protein A and Protein G Montage Spin Columns
- Protein G Affinity Media
- General Considerations for Selecting Optimal Binding Conditions for the Montage Antibody Purification Kit with PROSEP-G Media
- Binding Kinetics of Montage Spin Columns

### Choosing between Protein A and Protein G Montage Spin Columns

Immunoglobulin G from most species consists of several subclasses with different biological properties. Four subclasses of IgG have been identified in human (IgG1, IgG2, IgG3, and IgG4) and in mouse (IgG1, IgG2a, IgG2b and IgG3). For immunological studies, it is often necessary to isolate one particular subclass of IgG from the other subclasses.

Protein G binds to all major Ig classes except IgM and therefore has a wider reactivity profile than Protein A. However, the binding of IgGs to Protein G is often stronger, making elution and complete recovery of the immunoglobulin more difficult. Interestingly, due to the lower cost of Protein A compared to Protein G, researchers tend to experiment first with Protein A, then Protein G. Protein A withstands harsher conditions used in cleaning and regeneration.

The affinity of interaction of Protein A with mouse IgG subclasses varies. The most common subclass of mouse monoclonal antibodies is IgG1. Customization of the purification strategy may be required for the affinity separation as mouse IgG1 does not generally bind well to Protein A. However, as the affinity interaction is pH and salt dependent, under high salt regimes (2–3 M NaCl) and high pH (pH 8–9), the antibodies will bind to Protein A.

**Table 1. Physical Properties of Immunoglobulin Subclasses**

Immunoglobulin	IgG1	IgG2	IgG3	IgG4	IgM	IgA1	IgA2	sIgA	IgD	IgE
Heavy chain	$\gamma_1$	$\gamma_2$	$\gamma_3$	$\gamma_4$	$\mu$	$\gamma_1$	$\alpha_1$	$\alpha_1$ or $\alpha_2$	$\delta_1$	$\epsilon_1$
Mean serum concentration (mg/mL)	9	3	1	0.5	1.5	3.0	0.5	0.05	0.03	0.00005
Sedimentation constant	7S	7S	7S	7S	19S	7S	7S	11S	7S	8S
Molecular weight	146,000	146,000	170,000	146,000	970,000	160,000	160,000	385,000	184,000	188,000
Molecular weight of heavy chain	51,000	51,000	60,000	51,000	65,000	56,000	52,000	52-56,000	69,700	72,500
Number of heavy chain domains	4	4	4	4	5	4	4	4	4	5
% Carbohydrate	2-3	2-3	2-3	2-3	12	7-11	7-11	7-11	9-14	12

See reference 6 in "References" section on page 8.

**Table 2. Relative Affinity of Protein A and Protein G**

Key code for relative affinity of Protein A and G for respective antibodies:

++ = Strong affinity      + = Moderate/slight affinity      +/- = Requires evaluation      – = No affinity

	Protein A	Protein G		Protein A	Protein G		Protein A	Protein G
Human IgG <sub>1</sub>	++	++	Mouse IgM	+/-	–	Sheep IgG	+/-	+
Human IgG <sub>2</sub>	++	++	Rat IgG	++	++	Goat IgG	+/-	+
Human IgG <sub>3</sub>	–	++	Rat IgG <sub>1</sub>	+/-	+	Pig IgG	++	++
Human IgG <sub>4</sub>	++	++	Rat IgG <sub>2a</sub>	+/-	++	Chicken IgG	–	+/-
Human IgA	+	–	Rat IgG <sub>2b</sub>	+/-	+	<i>Fragments</i>		
Human IgD	+	–	Rat IgG <sub>2c</sub>	+/-	+	Human Fab	+	+
Human IgE	+	–	Rat IgM	+/-	–	Human F(ab') <sub>2</sub>	+	+
Human IgM	+	–	Rabbit IgG	++	++	Human scFv	+	–
Mouse IgG <sub>1</sub>	+	+	Hamster IgG	+	++	Human Fc	+	+
Mouse IgG <sub>2a</sub>	++	++	Guinea Pig IgG	++	+	Human $\kappa$	–	–
Mouse IgG <sub>2b</sub>	++	++	Bovine IgG	+	+	Human $\lambda$	–	–
Mouse IgG <sub>3</sub>	+	++						

See references 1–5 in "References" section on page 8.

## Protein G Affinity Media

Protein G is a cell wall protein from *Streptococci* with a molecular weight of 22 kDa. The covalent immobilization of the Protein G is important to avoid leakage of Protein G during the elution procedure. PROSEP-G consists of recombinant Protein G covalently immobilized on porous glass that is more rigid and durable than conventional polymeric matrices. Porous glass also has a very high uniform internal pore size distribution that falls within a very narrow range, resulting in uniform rates of diffusion and hence rapid mass transfer between solution and solid phase. The Protein G that is immobilized is a recombinant protein from which the albumin binding region has been deleted. Immobilized Protein G binds specifically to the Fc region of immunoglobulin molecules of many mammalian species. In many instances antibodies bind more strongly to Protein G than Protein A. PROSEP-G can be used to purify antibodies that may be difficult or impossible to purify on PROSEP-A High Capacity Media (for example, Rat IgG<sub>2b</sub> and Human IgG<sub>3</sub>). Excellent yields have been established using PROSEP-G resin with polyclonal rat, rabbit, and human antibodies.

Protein G affinity chromatography is a rapid one-step purification, which removes most non-IgG contaminants and can achieve purities close to homogeneity. It is particularly useful for purifications of tissue culture supernatant, where 10- to 100-fold concentrations can be achieved.

## General Considerations for Selecting Optimal Binding Conditions for the Montage Antibody Purification Kit with PROSEP-G Media

Any antibody-containing sample, such as a crude biological extract, a cell culture supernatant, serum, or ascites can be used in the Montage spin column. It is important that the sample is first filtered through a 0.22 µm Steriflip-GP filter unit to remove particulates that could clog the media flow channels. This is critical for re-use of the device. All samples should be filtered just prior to loading even if they have been filtered several days before the chromatographic run. Aggregation/precipitation of proteins is common during storage and repeated freeze/thaw cycles in sera, ascites, and tissue culture supernatants. Lipids, which can be found at high levels in serum or ascites, should also be removed (see Delipidation Procedure on page 7). Millipore recommends that samples from only one source be run on any given column.

In Protein G separations, the sample should simply be diluted 1:1 (v/v) in 1 × binding buffer.

### Eluting the Antibody from a PROSEP-G Spin Column

The most common elution conditions for Protein G affinity separations involve a reduction in pH to pH 2.5. It is important to appreciate that a few proteins (e.g., some monoclonal antibodies) are acid-labile and they can lose their activity at very low pH values. Above all, the elution conditions must preserve the integrity and activity of the target protein. Most observed denaturation is caused by harsh elution conditions. Acidic pH is known to reduce the antibody titre, decrease immunoreactivity and distort the antibody structure. It is therefore critical that the pH is restored to neutrality immediately after elution.

### Binding Kinetics of Montage Spin Columns

Controlling the flow rate through an affinity chromatography support is important in achieving binding. Flow rate through the column support is inextricably related to the efficiency of the separation; too fast a flow will cause the mobile phase to move past the beads faster than the diffusion time necessary to reach the internal bead volume. Our studies demonstrate that the large internal surface area of the Montage media bed compensates completely for the velocity of the mobile phase through the column support when the centrifugal speed does not exceed 1,000 × g\*. The Protein G media chemistries used in the Montage spin column have sufficiently rapid association kinetics between the protein molecule and the immobilized ligand to allow for optimal diffusional flow through the internal bead structure. Traditionally, gravity flow chromatography is very slow and resolution of the protein separation can be adversely affected by secondary diffusion effects.

\* No performance data is available for centrifugal speeds greater than 1,000 × g for wash steps.

# Purifying Antibodies

This section outlines the information necessary to purify antibodies using the Montage Antibody Purification Spin Columns with PROSEP-G Media, including information about preparing the buffers for those not using the kit.

- Loading the Media Plugs into the Spin Columns
- Pre-equilibration
- Sample Clarification
- Sample Loading
- Washing
- Elution
- Regeneration
- Desalting and Concentrating

## Protein G Kit Buffer Formulation

Use the following recipes to prepare the buffers supplied with the Montage Antibody Purification Kit with PROSEP-G Media. All buffers contain 0.1 % sodium azide as a preservative and can be stored at room temperature.

**Binding Buffer A** (1.5 M Glycine/NaOH buffer, 3 M NaCl, pH 9.0) Add 112.6 g glycine (free base; MW 75.07), 175.3 g NaCl (MW 58.44), 1.0 g sodium azide to 800 mL distilled water. Titrate with 5 M NaOH to pH 9.0. Make up final volume to 1 L with distilled water.

**Elution Buffer B2** (0.2 M Glycine/HCl buffer pH 2.5) Add 15.0 g glycine (free base; MW 75.07), 1.0 g sodium azide to 900 mL distilled water. Titrate with 5 M HCl to pH 2.5. Make up final volume to 1 L with distilled water.

**Neutralization Buffer C** (1 M Tris/HCl buffer pH 9.0) Add 103.72 g Tris base (MW 121.1), 22.72 g Tris hydrochloride (MW 157.6), 1.0 g sodium azide to 800 mL distilled water. Make up final volume to 1 L with distilled water.

## Loading the Media Plug into the Spin Column

1. Unwrap the sealing film from both ends of the plug.
2. Remove top and bottom caps.

NOTE: The dot on the top cap is red for PROSEP-A media plugs and yellow for PROSEP-G plugs. Once the caps are removed, the top end can be identified because it is recessed (approximately 2 mm deep).

3. Insert the plug into the spin column with the top (recessed) end uppermost.

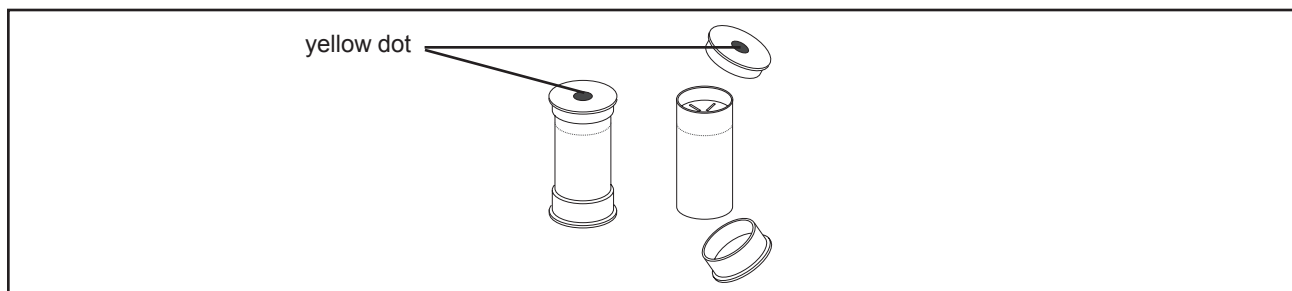

4. Push the plug fully into the tapered end of the spin column using the insertion tool.

NOTE: To remove the plug from the spin column, insert the tool into the bottom of the spin column and push upward.

## Antibody Purification Protocol

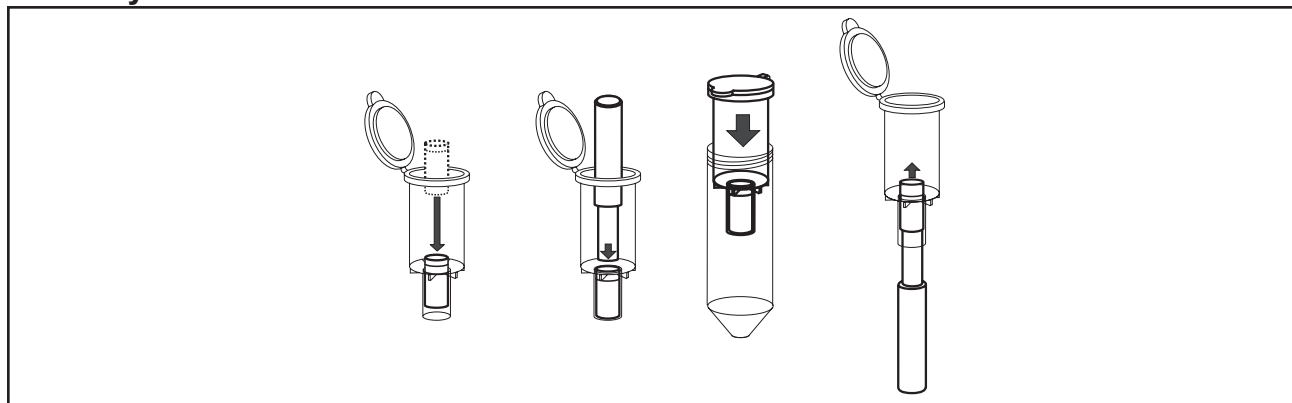

After loading the plug into the spin column and placing the spin column into a centrifuge tube, follow the procedure below.

#### PRE-EQUILIBRATION

1. Equilibrate the PROSEP-G media with 10 mL Binding Buffer A by centrifuging the spin column at  $500 \times g$  for 5 minutes.  
NOTE: If using one spin column, ensure that the spin column is counterbalanced with a unit of equal weight (adjusted with distilled water; without a plug).

#### CLARIFICATION OF SAMPLE

2. Pre-filter the sample (e.g., tissue culture supernatant, serum, or ascites) through a  $0.22 \mu\text{m}$  Steriflip-GP device to remove any debris immediately before loading the sample. Protein precipitation is common during storage and during repeated freeze/thaw cycles in ascites, sera, and tissue culture supernatants. Newly formed aggregates and precipitating protein complexes can foul the PROSEP-G media plug and result in significantly slower flow rates. Ensure that the samples are filtered **immediately** before loading, using filters with pore sizes no greater than  $0.22 \mu\text{m}$ . It is critical to the optimal performance of these devices that these instructions are rigorously followed. For antibody samples containing lipids and lipoproteins, refer to the delipidation procedure on the next page.

NOTE: For more details on Steriflip filter units, please go to [www.millipore.com](http://www.millipore.com) and search for **Steriflip User Guide** in the **Technical Library**.

#### SAMPLE LOADING

3. Dilute the filtered sample 1:1 v/v in Binding Buffer A. (For example, add 10 mL filtered sample to 10 mL buffer.) Pipette the 20 mL sample into the spin column. Centrifuge the spin column at  $100\text{--}150 \times g$  for 20 minutes. Ideal sample loading conditions are obtained using a flow rate of less than 1 mL/min. It may be necessary to increase the spin time or spin speed if any sample remains on top of the plug. A flow rate slower than expected may be indicative of a partially clogged plug resulting from incomplete filtration of the sample.

NOTE: If using one spin column, ensure that the spin column is counterbalanced with a unit of equal weight (adjusted with distilled water; without a plug).

#### WASHING

4. Wash the spin column to remove unbound contaminants by adding 10 mL Binding Buffer A and centrifuging the spin column for 2 minutes at  $500 \times g$ . Add another 10 mL Binding Buffer A and centrifuge for 2 more minutes at  $500 \times g$ . The unbound wash will contain non-immunoglobulin components. A flow rate slower than expected may be indicative of a partially clogged plug resulting from incomplete filtration of the sample. In the unlikely event that flow rates are significantly slower than those expected, increase the centrifugal speed to  $1000 \times g$  with 5 minute spin time intervals.

#### ELUTION

5. Elute the bound IgG with 10 mL Elution Buffer B2 directly into a fresh centrifuge tube containing 1.3 mL Neutralization Buffer C to bring the sample to neutral pH. Centrifuge the spin column for 5 minutes at  $500 \times g$ . A flow rate slower than expected may be indicative of a partially clogged plug resulting from incomplete filtration of the sample. In the unlikely event that flow rates are significantly slower than those expected, increase the centrifugal speed to  $1000 \times g$  with 5 minute spin time intervals.

#### REGENERATION

6. Wash the media with 10 mL Elution Buffer B2 by centrifuging the spin column at  $500 \times g$  for 5 minutes. Re-equilibrate the media with 5 mL of Binding Buffer A by centrifuging the spin column at  $500 \times g$  for 2 minutes. For immediate re-use, wash with 5 mL of Binding Buffer A, or, for use later, store the plugs without their end caps in 5 mL of Binding Buffer A in a 15 mL screw-capped tube.

#### DESALTING AND CONCENTRATING

7. If necessary, desalt and concentrate the antibody preparation using the Amicon Ultra-15 centrifugal filter device with 30,000 kDa NMWL, supplied in the Montage kit. Add 0.05–0.5% w/v sodium azide if the antibodies are to be stored at  $2\text{--}8 \text{ }^\circ\text{C}$ . We recommend freezing the antibodies in small aliquots in 50% glycerol at  $-20 \text{ }^\circ\text{C}$  for long term storage.

NOTE: For more details on Amicon Ultra-15 filter devices, please go to [www.millipore.com](http://www.millipore.com) and search for **Amicon Ultra User Guide** in the **Technical Library**.

## Delipidation Procedure

All Protein A and G affinity columns are affected by the presence of lipids and lipoproteins, especially in antibody samples derived from ascites fluid. For end users who have antibody solutions that they need to delipidate, the following protocol provides a gentle and easy method for removing lipids and lipoproteins.

1. Add 0.04 mL 10% dextran sulphate solution and 1 mL 1 M calcium chloride per mL of sample.
2. Mix for 15 minutes.
3. Centrifuge at  $10,000 \times g$  for 10 minutes.
4. Discard the precipitate.
5. Exchange the sample into TBS (Tris Buffered Saline) using an Amicon Ultra-15 device (Millipore Cat. No. UFC9 030 24), dialysis, or a desalting column. Do not buffer exchange into a phosphate-containing buffer such as PBS.

## Optional Quantitation Procedure

By using the Beer-Lambert law,  $A = \epsilon \cdot c \cdot l$ , the concentration of IgG (mg/mL) in the sample can be measured by multiplying the absorbance at 280 nm by 0.72. If IgM or IgA are purified, multiply the absorbance at 280 nm by 0.84 or 0.94, respectively. These antibody concentrations are only estimates as other contaminating proteins can also contribute to the absorbance reading. However, they can provide a reliable and quantitative method for determining the concentrations of pure antibody solutions. Most researchers use different sandwich ELISA assays to accurately measure antibody concentrations within ranges of 0.01 mg/mL to 20 mg/mL.

## Product Performance

The antibodies were monitored for purity by SDS-PAGE under reducing or non-reducing conditions. Note that IgG appears in a reducing SDS-PAGE as 25 kDa and 50-55 kDa bands. Recovery of immunoglobulins can be quantified by a standard protein assay, scanning densitometry of reducing or non-reducing SDS-polyacrylamide gels or ELISA. Antigen binding parameters can be measured for both affinity and avidity.

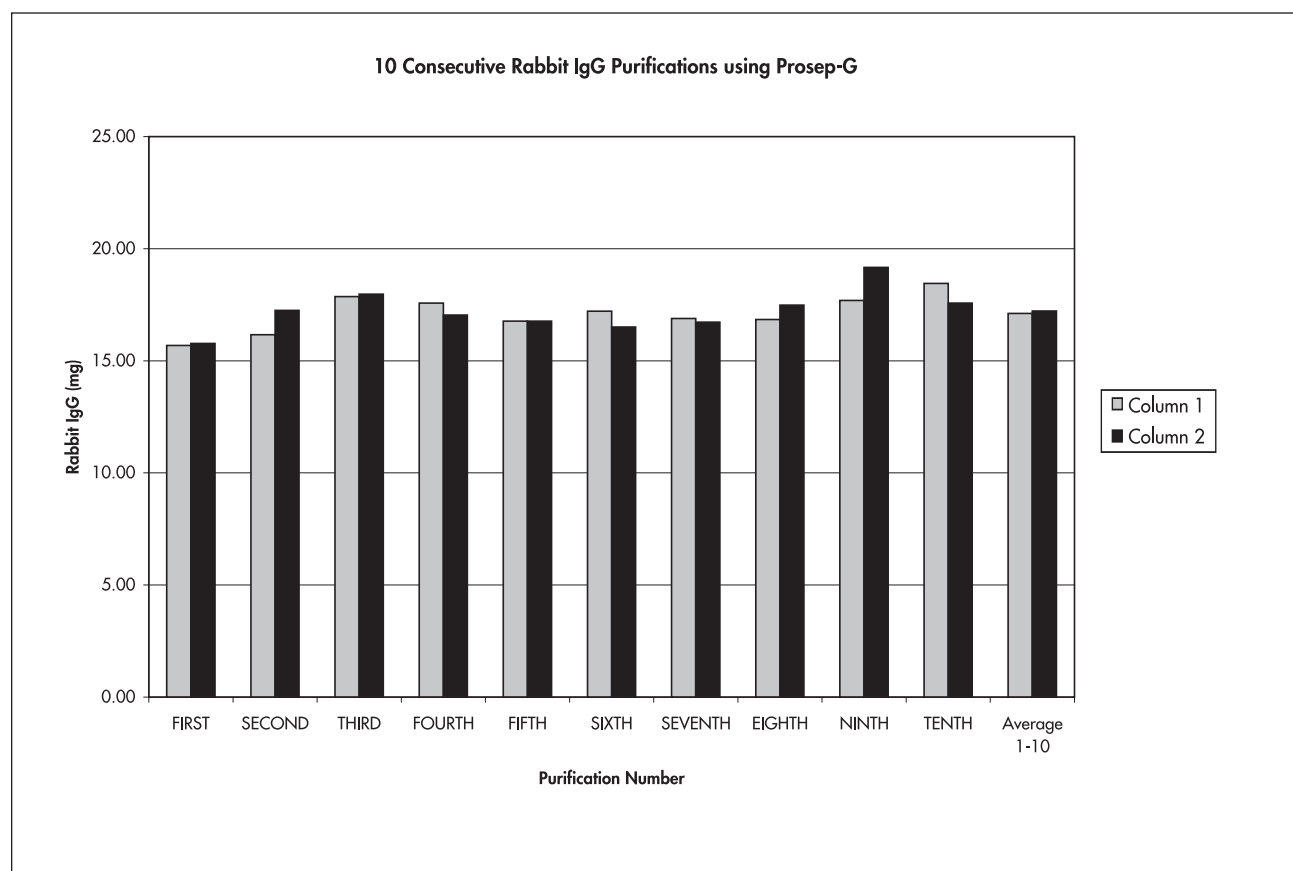

Rabbit IgG was purified in duplicate 10 consecutive times from normal rabbit serum using two different regenerated PROSEP-G spin columns with Binding Buffer A and Elution Buffer B2. An average of 17.1 mgs Rabbit IgG was purified with a CV = 4.7% and 5.3% respectively.



# PROSEP-G Media Plug Specifications

Source: Recombinant Protein G expressed in *E. coli*

Supporting matrix: Porous glass

Media particle size: 75 µm–125 µm

Media bed volume: 1.6 mL

Recommended working pH: pH 2.0–9.0

Binding capacity: typically > 15 mg rabbit IgG

Solubility in water: Insoluble

Maximum volume in swinging bucket rotor: 20 mL

## Chemical Compatibility of the Montage Spin Columns

All resins are susceptible to oxidative agents. Avoid high temperatures. Protein G is resistant to limited exposure to 8 M urea pH 10.5 and extremes of pH (e.g. pH 1.0 and pH 11). It lacks the robustness of Protein A with respect to 1 M NaOH and it is denatured under these aggressive conditions. However, Protein G is stable to treatment with 0.1 M NaOH.

## Troubleshooting Assistant

*The sample does not flow easily through the spin column*

- Pre-filter the sample just before loading onto the Montage spin column to prevent media from becoming clogged with particulates.
- Delipidate ascites before use to prevent media from becoming clogged with particulates. Refer to page 7 for the recommended delipidation procedure.
- Store used spin columns under recommended conditions. If the spin columns were not stored at 2–8 °C, or they have been used more than once and stored without a bacteriostat, microbial growth in the column may have restricted flow through the media plug.
- Increase the spin time or spin speed for the sample loading step. Refer to page 6 for recommended spin speeds.
- Increase the spin speed for the wash step. Refer to page 6 for recommended spin speeds.

*No elution of the target protein is observed from the spin column*

- Prepare new solutions to ensure that the pH of the elution buffer is correct.
- Optimize the elution buffer to ensure that the elution conditions are sufficient to desorb the target protein. Refer to page 6 for recommended elution conditions.

*Decrease in performance after repeated use*

- Prepare a fresh sample; the nature of the sample may have changed during handling or storage.
- Keep sample load parameters consistent from run to run.
- Use elution conditions which stabilize the sample to prevent proteins or lipids from precipitating in the media bed.
- Prepare new buffers to ensure that buffer pH and ionic strength are correct.

## References

1. Richman, D. D., Cleveland, P. H., Oxman, M. N. and Johnson, K. M. 1982. "The binding of *Staphylococci* protein A by the sera of different animal species." *J. Immunol.* 128: 2300-2305.
2. Akerstrom, B., Brodin, T., Reis, K. and Bjork, L. 1985. "Protein G: A powerful tool for binding and detection of monoclonal and polyclonal antibodies." *J. Immunol.* 135: 2589-2592.
3. Gagnon, P. 1996. "Protein A Affinity Chromatography." In: Gagnon, P., ed. *Purification Tools for Monoclonal Antibodies.* 155-198. Validated Biosystems Inc., Tucson.
4. Swartz, L. 1990. In: Boyle, M., ed. *Bacterial Immunoglobulin-Binding Proteins.* Vol II:309. Academic Press, San Diego.
5. Frank, M. B. 1997. "Antibody Binding to Protein A and Protein G beads". In: Frank, M. B., ed. *Molecular Biology Protocols.* (<http://omrf.ouhsc.edu/~frank/ProteinA.html>). Oklahoma City. Revision Date: January 3, 2001.
6. Steward, M. W. 1984. "Structure and biological activities of its immunoglobulin classes. In: Steward, M. W. *Outline Studies in Biology Antibodies: Their Structure and Function.* Chapter 5. Chapman and Hall, NY.



## Product Ordering Information

This section lists the catalogue numbers for the Montage Antibody Purification Kits and Spin Columns with PROSEP-G and PROSEP-A Media. See the Technical Assistance section for information about contacting Millipore. You can also buy Millipore products on-line at [www.millipore.com/products](http://www.millipore.com/products).

Description	Catalogue Number	Qty/Pk
<b>Kits</b>		
Montage Antibody Purification Kit with PROSEP-G Media (contains buffers, spin columns, media plugs, insertion tool, Steriflip filter units, Amicon Ultra filter devices, centrifuge tubes)	LSK2 ABG 20	Kit to process 20 samples
Montage Antibody Purification Kit with PROSEP-A Media (contains buffers, spin columns, media plugs, insertion tool, Steriflip filter units, Amicon Ultra filter units, centrifuge tubes)	LSK2 ABA 20	Kit to process 20 samples
<b>Spin Columns</b>		
Montage Antibody Purification with PROSEP-G Media Spin Columns	LSK2 ABG 60	6 columns to process 60 samples
Montage Antibody Purification with PROSEP-A Media Spin Columns	LSK2 ABA 60	6 columns to process 60 samples
<b>Accessories</b>		
Steriflip Filter Units	SCGP 005 25	25
Amicon Ultra-15 Centrifugal Filter Devices	UFC9 030 08	8
	UFC9 030 24	24
	UFC9 030 96	96
Vacuum Pump (220 V, 50 Hz)	WP61 220 50	1
Vacuum Pump (115 V, 60 Hz)	WP61 115 60	1
Vacuum Pump (100 V, 50/60 Hz)	WP61 100 60	1
Tubing, silicone, 3/16 in. I.D × 4.5 ft (4.8 mm I.D. × 1.4 m)	XX71 000 04	1
Stopper, No. 8 perforated, silicone	XX10 047 08	5
Vacuum Filtering Flask, 1L	XX10 047 05	1
Millex®-FG <sub>50</sub> Filter Unit	SLFG 050 10	10

## Technical Assistance

For more information, contact the Millipore office nearest you. In the U.S., call **1-800-MILLIPORE** (1-800-645-5476). Outside the U.S., see your Millipore catalogue for the phone number of the office nearest you or go to our web site at [www.millipore.com/offices](http://www.millipore.com/offices) for up-to-date worldwide contact information. You can also visit the tech service page on our web site at [www.millipore.com/techservice](http://www.millipore.com/techservice).

Millipore Corporation is pleased to provide internet access to Material Safety Data Sheets (MSDS) for its products that contain hazardous materials. To obtain any MSDS documents that may be associated with this product, go to the MSDS page of our website at [www.millipore.com/msds.nsf/home](http://www.millipore.com/msds.nsf/home).

## Standard Warranty

**Millipore Corporation** ("Millipore") warrants its products will meet their applicable published specifications when used in accordance with their applicable instructions for a period of one year from shipment of the products. **MILLIPORE MAKES NO OTHER WARRANTY, EXPRESSED OR IMPLIED. THERE IS NO WARRANTY OF MERCHANTABILITY OR FITNESS FOR A PARTICULAR PURPOSE.** The warranty provided herein and the data, specifications and descriptions of Millipore products appearing in Millipore's published catalogues and product literature may not be altered except by express written agreement signed by an officer of Millipore. Representations, oral or written, which are inconsistent with this warranty or such publications are not authorized and if given, should not be relied upon.

In the event of a breach of the foregoing warranty, Millipore's sole obligation shall be to repair or replace, at its option, the applicable product or part thereof, provided the customer notifies Millipore promptly of any such breach. If after exercising reasonable efforts, Millipore is unable to repair or replace the product or part, then Millipore shall refund to the customer all monies paid for such applicable product or part. **MILLIPORE SHALL NOT BE LIABLE FOR CONSEQUENTIAL, INCIDENTAL, SPECIAL OR ANY OTHER INDIRECT DAMAGES RESULTING FROM ECONOMIC LOSS OR PROPERTY DAMAGE SUSTAINED BY ANY CUSTOMER FROM THE USE OF ITS PRODUCTS.**

## Appendix A

### How to Convert RPM to G Force (RCF) Using a Swinging Bucket Rotor

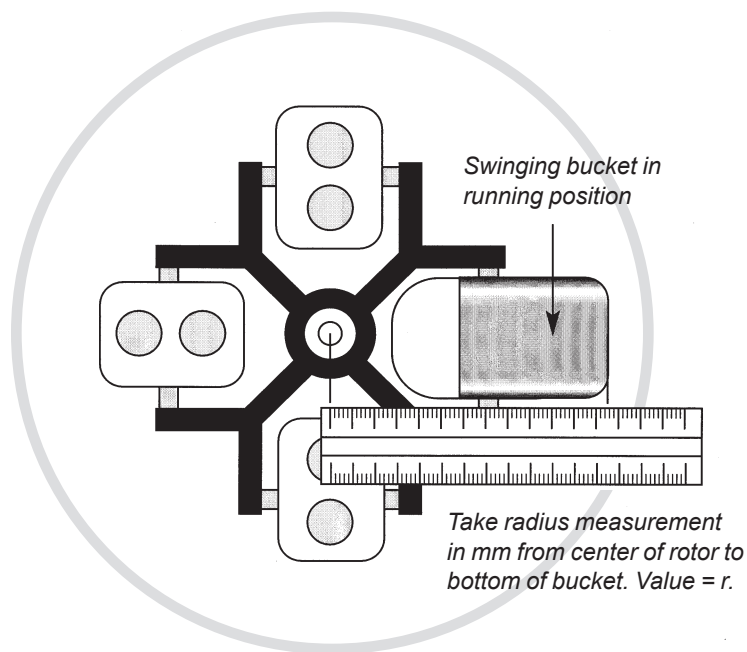

It is important that the Montage spin columns are centrifuged at the correct speeds. Use of higher speeds than those indicated may damage the media matrix and result in reduced performance. Many centrifuges display only rpm. See the diagram to enable accurate conversion between rpm and RCF (g force). This formula will work on any rotor providing an accurate measurement is taken from the center of the rotor to the bottom of the swinging bucket at its open position (when the bucket is rotated through 90° in its running position).

$$RCF = 1.12 \times r \left[ \frac{\text{rpm}}{1000} \right]^2$$

E.g., 1,000 × g corresponds to 2,360 rpm when the radius (r) = 160 mm.



*Millipore, Amicon, Millipore Express, Montage, PROSEP, Steriflip, Millex, and Ultracel are registered trademarks of Millipore Corporation  
The M mark is a trademark of Millipore Corporation.*