



## User Guide

# Steritest™ Symbio ISL Pump Installation Guide



The life science business of  
Merck KGaA, Darmstadt, Germany  
operates as MilliporeSigma in  
the US and Canada.

[www.sigmaaldrich.com](http://www.sigmaaldrich.com)

**Millipore®**

# Contents

Introduction.....	3
System overview.....	3
Additional Features.....	3
About this Manual.....	4
Operator and Equipment Safety.....	4
Specifications and Operating Requirements.....	6
Overview of the ISL Pump Assembly.....	9
Preparing to Install the Pump in the Isolator.....	13
Preparing the Isolator.....	13
Installation recommendations .....	14
Unpacking the Equipment.....	17
Verifying that the Pump Functions Properly.....	19
Installing the Pump.....	23
Installing the Communication Hub under the Isolator.....	54
Installing the Communication Hub on the Side, High Version.....	54
Installing the Communication Hub on the Side, Low Version.....	56
Installing the Communication Hub below the Pump Housing.....	58
Accessories and Replacement Parts.....	59
Symbols Referenced.....	61
Standard Product Warranty.....	62
Technical Assistance.....	63



## Introduction

### System Overview

The Steritest™ Symbio peristaltic pumps are used for sterility testing and are available in three versions: LFH, ISL, and FLEX. Combined with optional accessories, the pumps provide a wide range of installation possibilities, allowing integration in all testing environments (laminar flow hood, biosafety cabinet, clean room, and isolator), including existing isolators without table rework.

The Steritest™ Symbio pumps have been designed to be used along with Steritest™ devices. Many type of sterile products can be tested with the Steritest™ system, including:

- Large- and small-volume parenteral solutions in glass or plastic bottles, collapsible bags, ampoules, and vials
- Pre-filled syringes
- Lyophilized and other soluble products in ampoules or vials
- Antibiotics in ampoules or vials
- Medical devices
- Difficult-to-dissolve powders

The easy-load automatic pump head facilitates the Steritest™ tubing placement in an isolator configuration and protects the user from the rotor.

A timer coupled with a rotor position compensation provides repeatability of small-volume sampling.

A pressure control system constantly monitors the pressure inside both canisters. An alarm signals pressure increases above the specifications. In regulation mode, the pump decreases the pump speed automatically until the pressure returns to normal.

The microorganisms present in the sample are captured on the Steritest™ canisters microporous membrane. Appropriate medium is pumped into each canister separately to promote the growth of the captured organisms. The canisters are incubated and examined for contamination in accordance with the relevant pharmacopoeia.

### Additional Features

Tests can be run in either the Standard Mode, in which filtration parameters are chosen manually, or in the Test Method Mode, in which every step of the method appears on the screen with preloaded parameters for speed and time to ensure there is no deviation from the approved test protocol. The test methods are created with the Steritest™ Symbio Software and transferred to the Steritest™ Symbio pump through a network cable or with USB flash drive.

The pump and PC software can be used in ten languages (German, English, Spanish, French, Italian, Portuguese, Japanese, Simplified Chinese, Russian, and Turkish). The drain tray and bottle holder are ergonomically positioned around the pump head for easy access in limited-space environments.



A wide range of optional accessories are available to improve the sterility testing workflow:

- A footswitch with two operation modes
- A glass ampoule breaker
- A support rod extension for hanging sterile bags or the Steridilutor® vent chamber
- A syringe support to facilitate the handling of pre-filled syringes (with or without needles), and to provide an automatic rinsing function
- A liquid waste overflow sensor that signals an alarm on the pump screen when the waste container is nearly full
- A tray that carries up to 5 Steritest™ canisters and an optional rack to hold up to 4 carrying trays
- A holder to attach the communication hub to one of the isolator feet
- A holder to attach the communication hub below the isolator table

#### NOTE

Go to [www.millipore.com/steritest-symbio](http://www.millipore.com/steritest-symbio) to check the latest version of this document and get information about Steritest™ Symbio Pump optional accessories.

## About this Manual

This manual details the procedure for the installation of the Steritest™ Symbio ISL pump in an isolator.

This procedure applies to isolator tables that are up to 7 mm thick. For thicker isolator tables, an adaptation kit is required. Contact our sales representative for more information.

All screen shots and drawings in this manual are examples and may vary depending on the pump version.

All dimensions indicated in the Steritest™ Symbio pumps pictures are in millimeters (mm).

## Operator and Equipment Safety

All employees who will operate and/or be near the Steritest™ Symbio pump must comply with the following:

- Read and understand this user guide before using the pump. Failure to follow installation and operating instructions could result in user injury or damage to the instrument.
- Read and understand all maintenance instructions in this user guide before performing maintenance on the pump. Failure to follow instructions could result in user injury or damage to the instrument.
- Any alteration of the pump from factory specification may cause unsafe conditions, and will void the product warranty.
- Any attempt to use the pump in a manner not specified in this user guide may result in damage to the instrument, operator injury, and will void the product warranty.





- Do not attempt to repair the pump. Service should be performed by trained and authorized personnel only.
- Place the pump on a clean, flat, stable, horizontal surface, away from any source of excessive heat and close to an easily accessible, properly grounded power supply outlet.
- Do not expose the pump or the communication hub to liquid. If this happens, immediately switch off and disconnect the pump from the power outlet, and then decontaminate the pump and communication hub surfaces. For cleaning instructions, see the **Steritest Symbio Pumps User Guide**.
- Never expose the equipment to extreme temperatures. Operating temperature must be between 15 °C and 40 °C (59 and 104 °F).
- Use only accessories and replacement parts designed for the pump. See [Accessories and Replacement Parts](#) in this user guide. For additional accessories and replacement parts, see the **Steritest Symbio Pumps User Guide**. Using accessories not designed for the pump could result in user injury or damage to the instrument.
- The Steritest™ Symbio Pump has been designed to be used with the Steritest™ devices and accessories.
- When filtrating hazardous liquids, wear and use proper protective clothing and equipment for the handling and the disposal of the liquid to be filtrated.
- In case of skin contact with the filtrated liquid, refer to the safety datasheet of the filtrated liquid for first aid measures.
- Dispose the filtrated liquids according to local regulations.
- Do not use the Steritest™ Symbio Pump to filtrate flammable products.
- Never touch the display or control panel with a sharp object.
- Before cleaning, shut down the Steritest™ Symbio Pump and switch off and disconnect the communication hub from the power source.
- The power supply must be protected by a fuse below the main connection.
- The electrical installation must comply with local standards.
- Use an electrical surge protector to prevent damage to the system.



## Specifications and Operating Requirements

Parameter	Value/Range	
<b>Dimensions and weight: ISL version, equipped pump</b>	Width	588 mm (23.1 in.)
	Depth	313 mm (12.3 in.)
	Height	354 mm (13.9 in.)
	Weight	17.6 kg (38.8 lb) 16.0 kg (35.3 lb) (without accessories)
	Pump head height	81 mm (3.2 in.)
<b>Performance specifications</b>	Rotation speed	up to 240 rpm
	Timer	from 0.5 to 999
<b>Materials of construction</b>	Pump housing	316L Stainless steel
	Pump housing flat seal	Silicone foam
	Pump housing screws	A2 Stainless steel
	Pump head protective cover housing	316L Stainless steel
	Pump head protective cover tubing guide	Polyphenylsulfone (PPSU)
	Pump head	316L Stainless steel
	Seal plate (closing system seal)	Polyoxymethylene (POM)
	Pump supports for drain tray and bottle holder	316L Stainless steel
	Screen pane/window	Toughened glass
	Screen housing	316L Stainless steel
	Screen housing seals	Ethylene propylene diene monomer (EPDM)
	Screen seal	Silicone
	Pump control panel / key pad	Polyester
	Rotary control knob	316L Stainless steel
	Rotary control knob seals	Ethylene propylene diene monomer (EPDM)
	Pump power inlet	Chrome-plated brass
	Pump feet	Rubber
	Pump feet screws	A2 Stainless steel
	Threaded stems (for installation)	A2 Stainless steel
	<b>Drain tray</b>	
	Drain tray container	Polyphenylsulfone (PPSU)
	Drain tray support	316L Stainless steel
	Drain tray support seal	Ethylene propylene diene monomer (EPDM)
	Steritest™ canisters carrying trays	Polyphenylsulfone (PPSU)



<b>Materials of construction</b>	<b>Bottle holder</b>	
	Bottle holder support rod	316L Stainless steel
	Bottle holder basket	316L Stainless steel
	Bottle holder fastening screw clip	Polyphenylsulfone (PPSU)
	<b>Communication hub</b>	
	Housing	316L Stainless steel with epoxy paint
	Feet	Nylon and ethylene vinyl acetate (EVA)
	USB port	Nickel-plated brass and polybutylene terephthalate (PBT)
	Fuse holder	Thermoplastic+tin-plated copper alloy
	Ethernet port	Nickel-plated brass and polybutylene terephthalate (PBT)
	Communication ports (for footswitch, etc...)	Nickel-plated brass and polybutylene terephthalate (PBT)
	Power inlet	Polyamide 6.6 and nickel-plated steel
	Pump connection cable	Polyvinyl chloride (PVC)
	Pump connection cable grommet	Nickel-plated brass
Pump connection cable connector	Chrome-plated brass	
<b>Electrical Specifications</b>	Power supply voltage	100 to 240 Volt AC, 50/60 Hz
	Input to pump	24 Volt DC
	Power	140 W
<b>Operating Requirements</b>	Ambient temperature	15 to 40 °C (59 to 104 °F)
	Relative humidity	< 90%
	Altitude	< 2000 meters (6561 feet)
	Filtration units	Compatible with all Steritest™, Sterisolutest®, Steridilutor® and liquid transfer kits
	Protection type (IEC 60529-2004)	IP64 for the pump
	Sound intensity	<70 dB



<p><b>Regulatory Information</b></p>	<p>Millipore SAS certifies that the Steritest™ Symbio 3-Media Pump is designed and manufactured in application of:</p> <ul style="list-style-type: none"> <li>• The following European Council directives: <ul style="list-style-type: none"> <li>- Electromagnetic compatibility 2014/30/EU</li> <li>- Low voltage directive 2011/65/EU</li> <li>- Restriction of the use of certain Hazardous Substances in electrical equipment (RoHS) 2011/65/EC</li> </ul> </li> <li>• The following standards: <ul style="list-style-type: none"> <li>- IEC 61010-1: 2010 (Ed. 3) Safety requirements for electrical equipment for measurement, control and laboratory use – Part 1: General requirements</li> <li>- IEC 61326-1: 2012 (Ed. 2) Electrical equipment for measurement, control and laboratory use -EMC requirements – Part 1: General requirements.</li> </ul> </li> </ul> <p>These standards include the national deviations as appropriate for the relevant countries: USA, Canada, Australia, Argentina, Brazil, China, India, Japan, Mexico, Russia, Saudi Arabia, South Africa, South Korea, Singapore</p> <ul style="list-style-type: none"> <li>• The Federal Communications Commission (FCC) standard and test method: <ul style="list-style-type: none"> <li>- Standard: <ul style="list-style-type: none"> <li>FCC part 15: 2014 Code of federal regulations</li> <li>Title 47 – Telecommunication chapter 1- Federal Communication Commission.</li> <li>Part 15 - Radio frequency devices Subpart B - Unintentional Radiators Limits and Methods of measurement of radio disturbance.</li> </ul> </li> </ul> </li> <li>• Test method: <ul style="list-style-type: none"> <li>Section 15 .107 - Information to the user Section 15 .109</li> <li>- Conducted limits</li> </ul> </li> <li>• The Administrative Measure on the Control of Pollution caused by Electronic Information Products (EIP-A) standard: SJ/T 11364-2006.</li> </ul>
--------------------------------------	---



# Overview of the ISL Pump Assembly

**NOTE**

Dimensions are in millimeters.

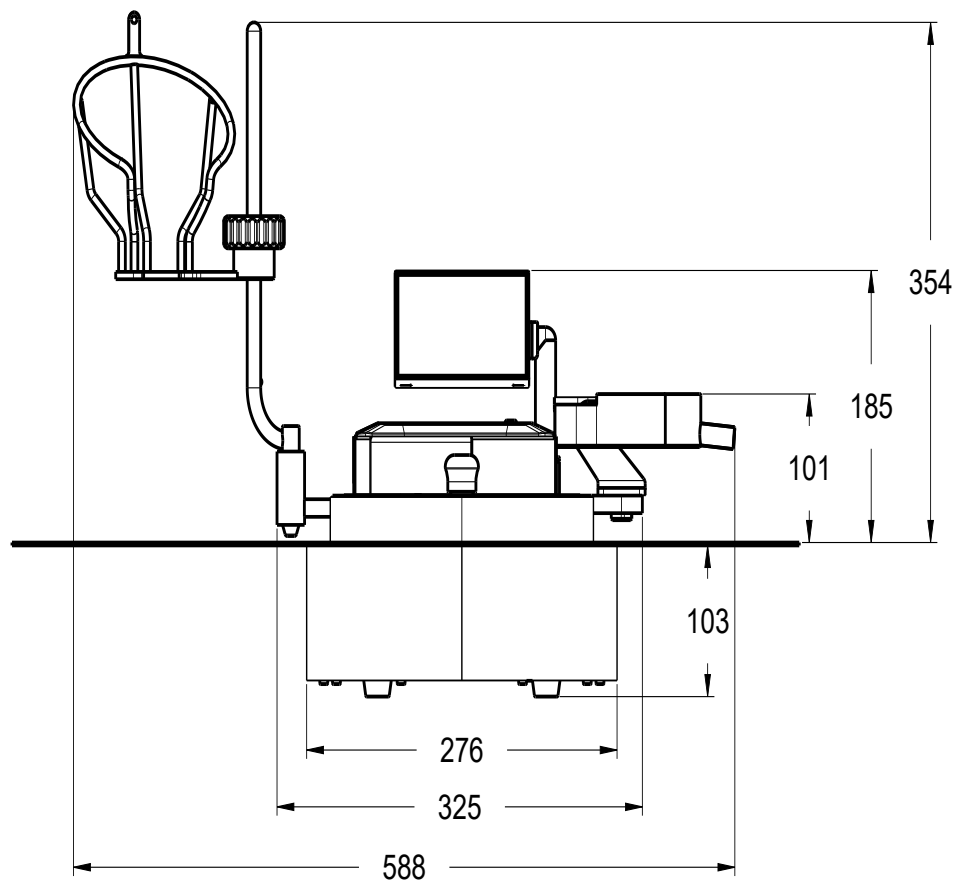
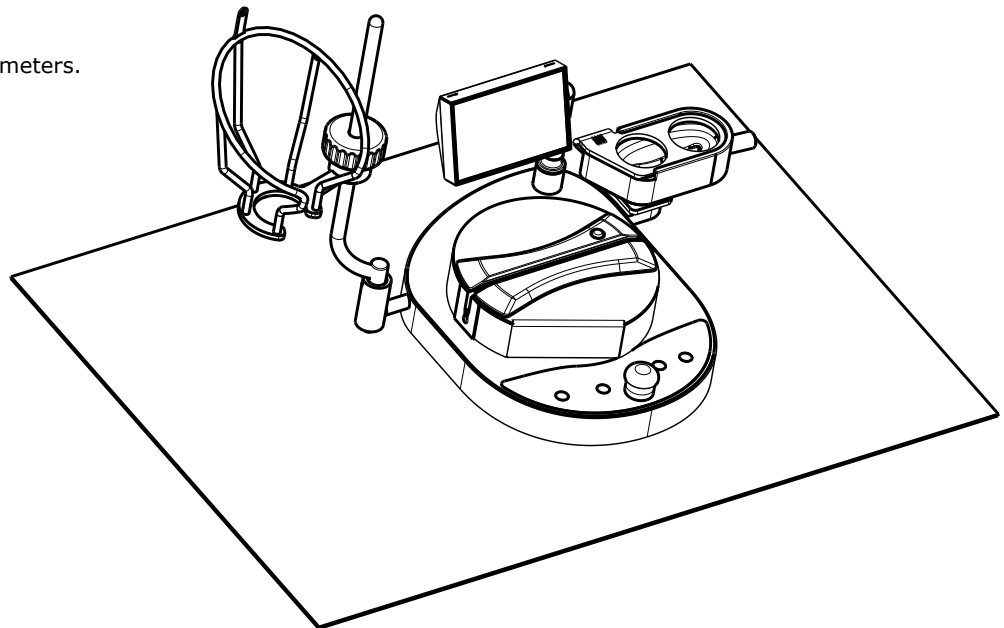

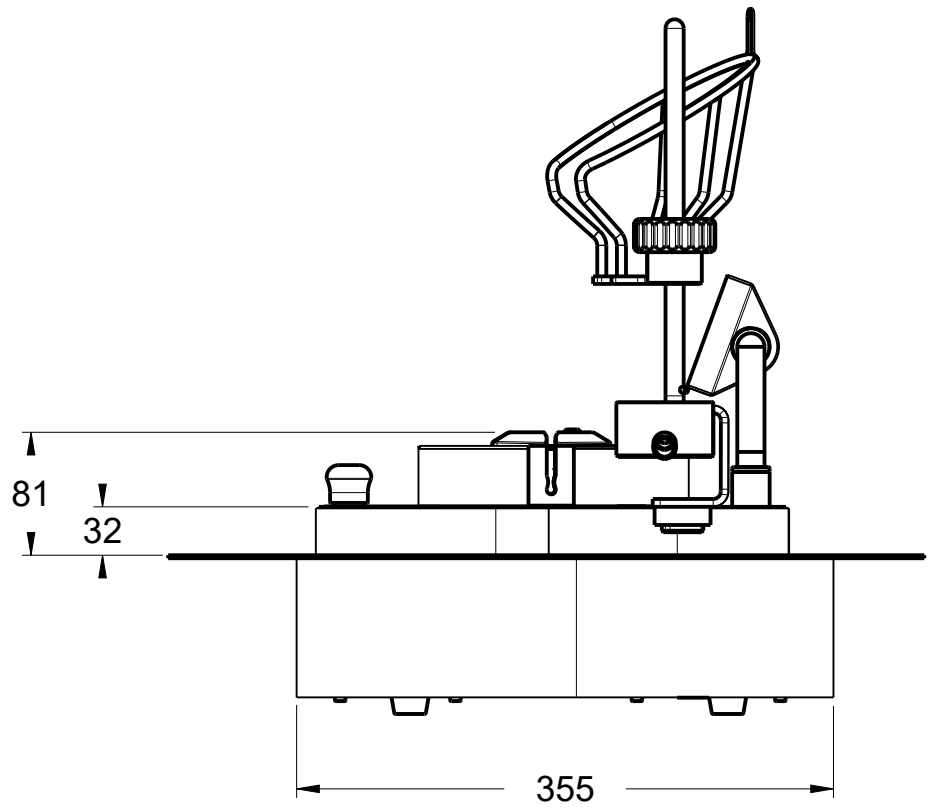
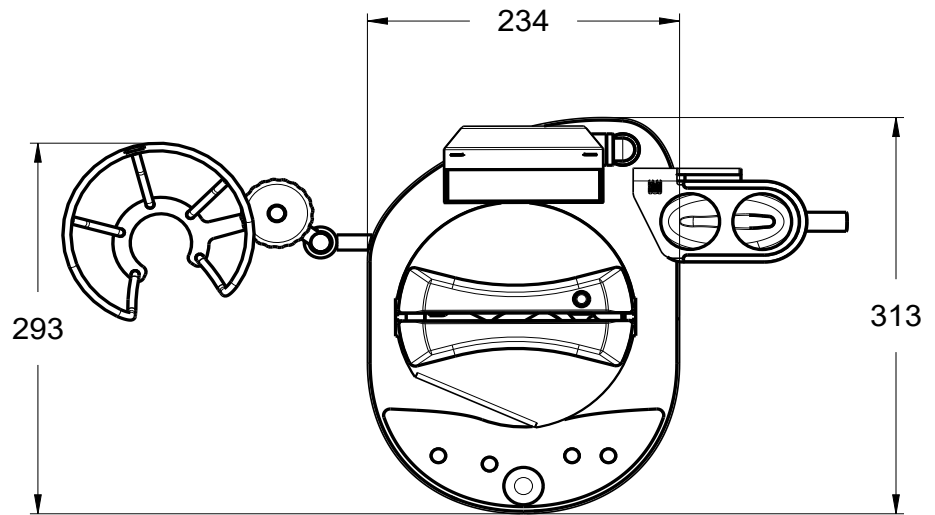

**The Steritest™ Symbio ISL pump assembly consists of:**

- The pump upper part (accessible on the isolator table), including:
  - A control panel on the front
  - An adjustable color display at the back
  - A pump head located below a protective cover
  - A bottle holder (mounted on the left side of the pump)
  - A drain tray (mounted on the right side of the pump)
- The pump lower part (located under the isolator table), including a case that contains the electrical and electronic components of the pump
- A communication hub equipped with a cable to connect it to the pump (located under the isolator table)
- A power cord

**Some additional accessories are delivered with the pump:**

- A network cable (for connecting the pump to a network or directly to a computer) for the transfer of test methods from a computer to the pump
- A USB flash drive for the transfer of test methods from a computer to the pump
- Silicone drain tubing for the disposal of liquid
- 2 threaded stems
- 2 Steritest™ canisters carrying trays

**WARNING**

Do not discard the Steritest™ canisters carrying trays. Deliver them to the final user of the pump.

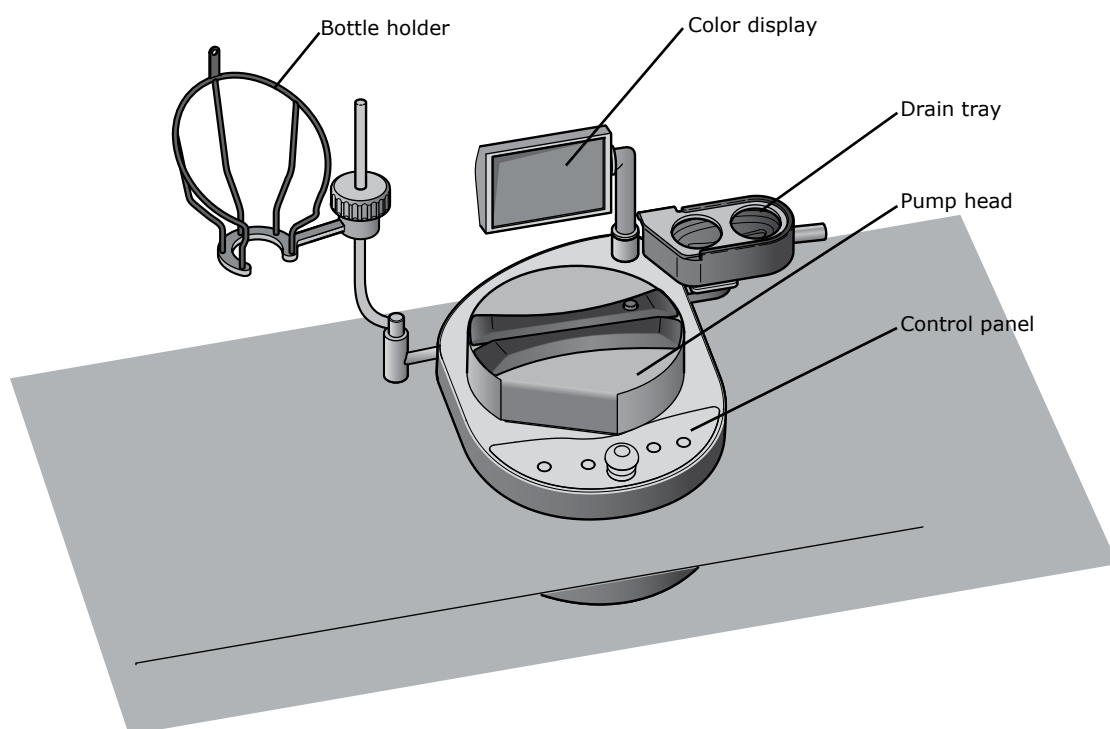

**Communication hub – front view:**

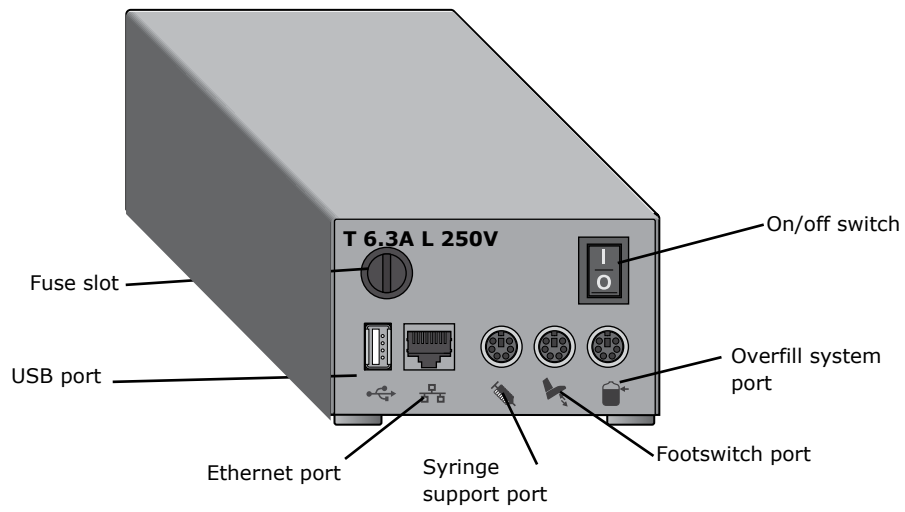

**Communication hub – rear view:**

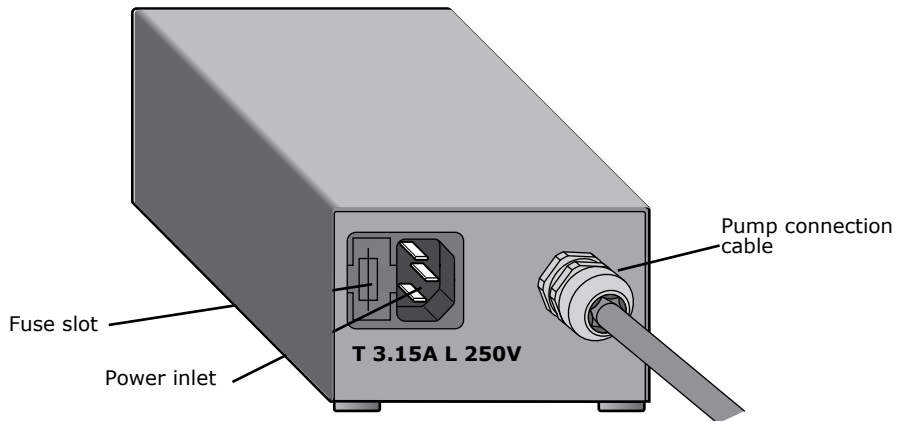



# Preparing to Install the Pump in the Isolator

## Preparing the Isolator

To install the Steritest™ Symbio ISL pump in the isolator, a specific cutout must be made in the table.

The cutout details and the recommended position of the drain in relation to the cutout are indicated in the following drawing.

### NOTE

The e-drawing file (.dxf) for this cutout is available at [www.millipore.com/steritest-symbio](http://www.millipore.com/steritest-symbio).

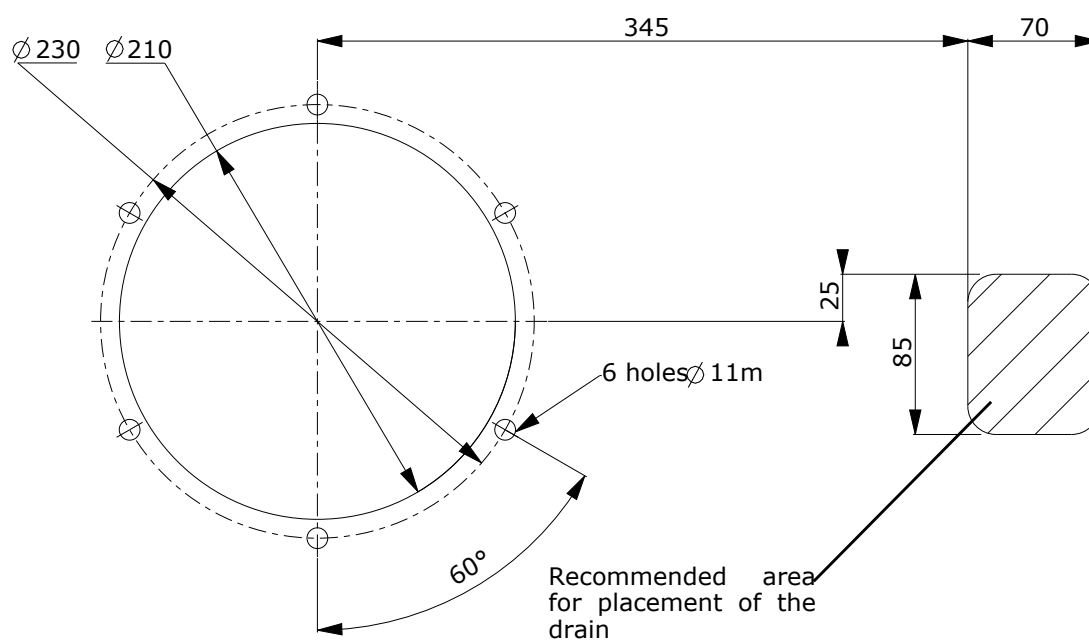

### NOTE

The cutout for the Steritest™ Symbio ISL pump is compatible with the cutout for the Steritest™ Integral Pump and the Steritest™ Equinox Isolator TQNXISL01. If a Steritest™ Symbio ISL pump replaces either of these two pumps, no modification of the isolator table cutout is required.



To ensure good flow of the liquid to the drain, the isolator table should be equipped with an elbow piece (oriented to the drain tray) to which the drain tubing can be connected.

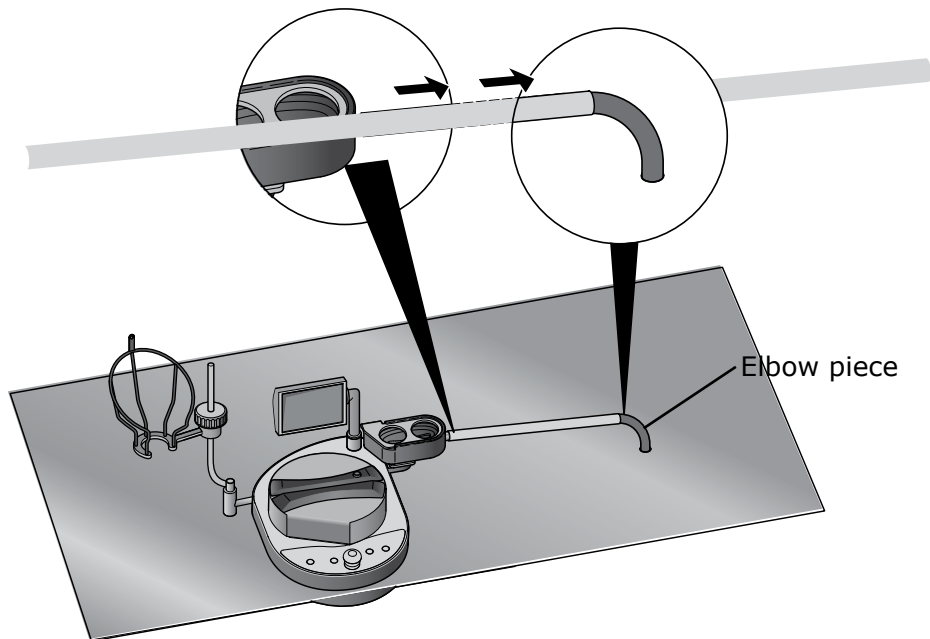

The height of the elbow piece should not exceed 50 mm to ensure that the drain tray is higher than this elbow piece.

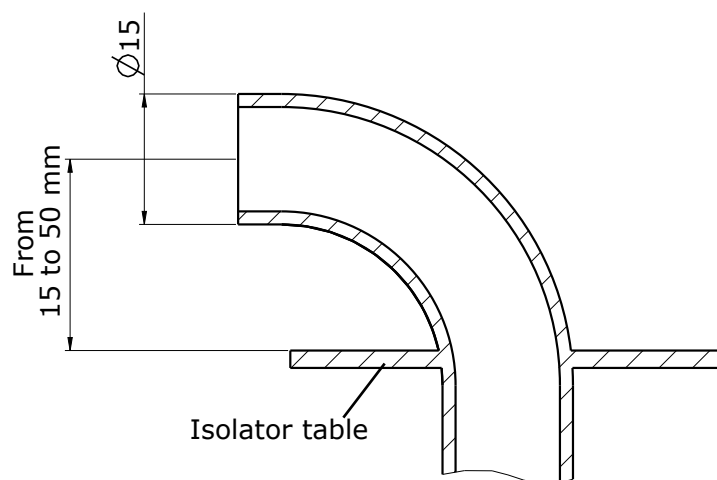

The position of the cutout on the isolator table must be defined according to the dimensions and contents of the isolator in order to avoid any interference and improve ergonomics.

The following drawing shows the size of the pump upper part (the part that is on the top of the isolator table), with its accessories, in relation to the cutout.

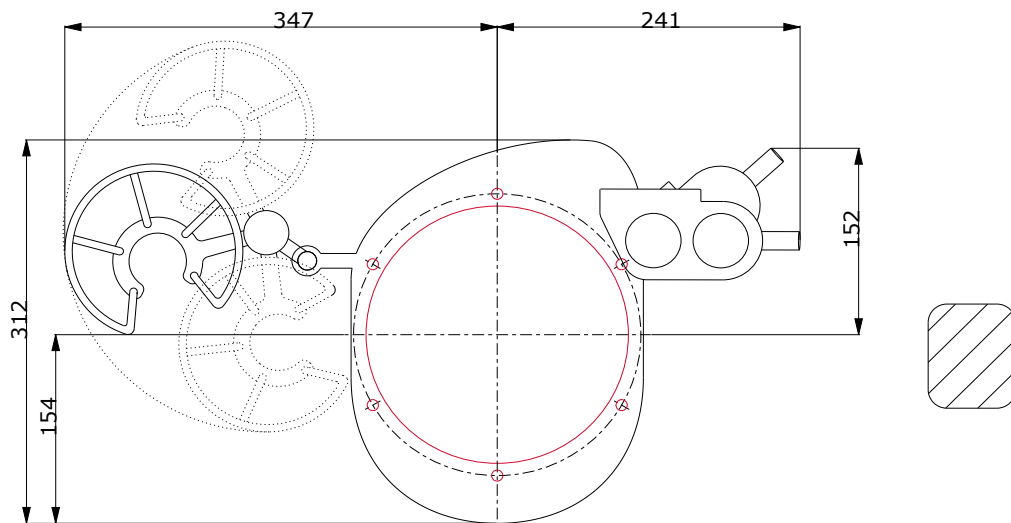

The following drawing shows the size of the pump bottom part (the part that is under the isolator table), with the drain position recommendation, in relation to the cutout. The height of the pump bottom part under the isolator table is 103 mm.

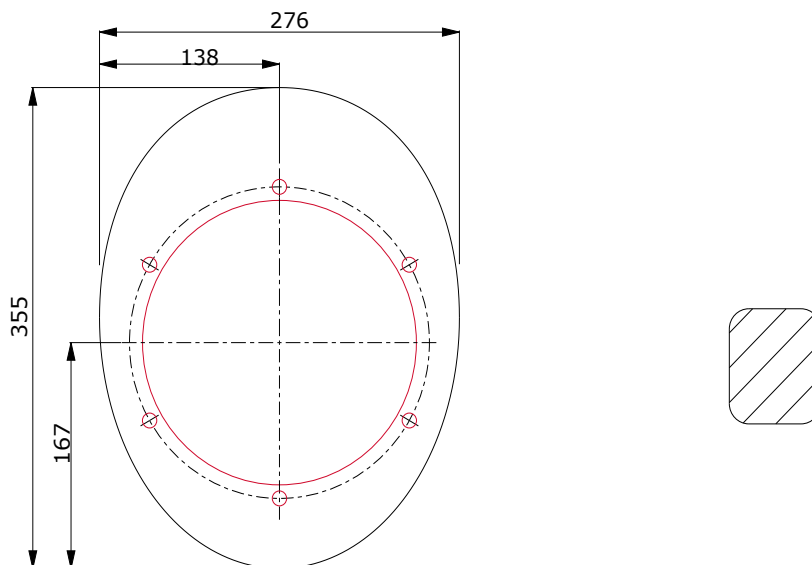

#### NOTE

The communication hub is not represented on this drawing. It can be attached in multiple positions under the isolator table using the optional Steritest™ Symbio communication hub holder for isolators (See [Installing the Communication Hub under the Isolator](#) and [Accessories and Replacement Parts](#)). It can also be fixed to one of the isolator feet, using the optional communication hub holder for hoods (see [Accessories and Replacement Parts](#)).



To ensure good working ergonomics, it is recommended that the center of the cutout be positioned between 282 and 307 mm from the isolator wall.

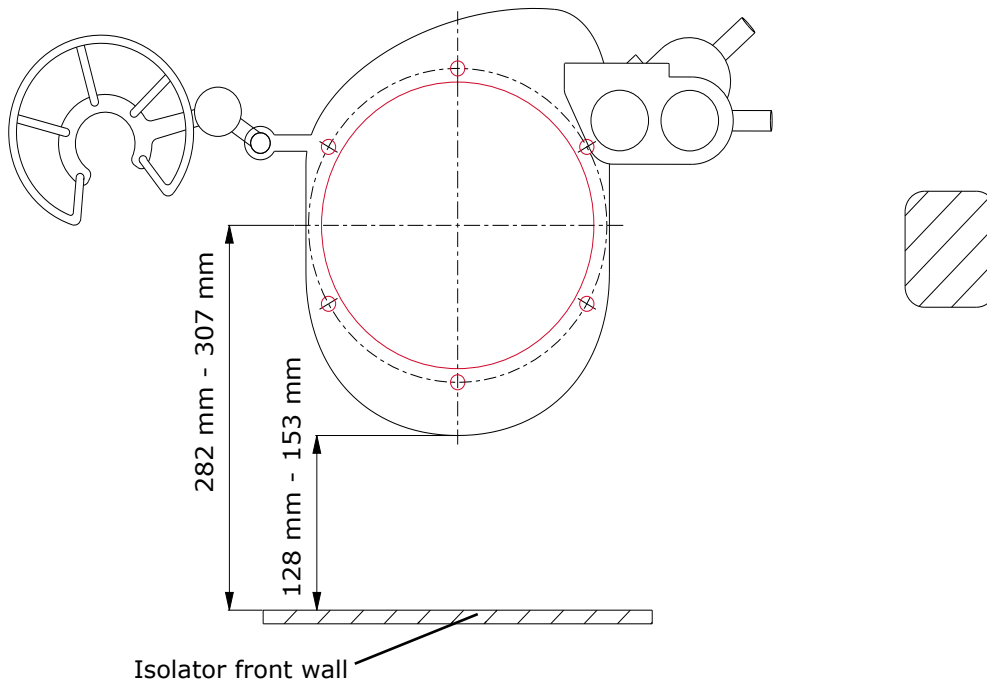

## Installation Recommendations

### Warning

The pump must be opened to proceed to the installation. This operation does not void the warranty. However, to preserve this warranty, it is mandatory to execute the short test cycles (before and after installation) described in this installation guide.

Use the Steritest™ Symbio Pumps Isolator Installation Checklist (PF17360) to document the proper execution of the installation steps and test cycles.

(Download the checklist at [www.millipore.com/steritest-symbio](http://www.millipore.com/steritest-symbio) )

Deliver this document to the end user of the pump.

### Tools Required

The following tools are required for the installation of the pump:

- A T20 star screwdriver
- A #3 hex key
- A #5 hex key

### Tightening the Screws

To ensure the tightness of the system, each time screws are installed throughout the installation procedure, tighten them evenly and equally.



## Precautions when Handling the Electronic Board



The electronic board is electrostatic sensitive. Observe precautions for handling.

## Unpacking the Equipment

The Steritest™ Symbio Pump is delivered in two boxes that are strapped together.

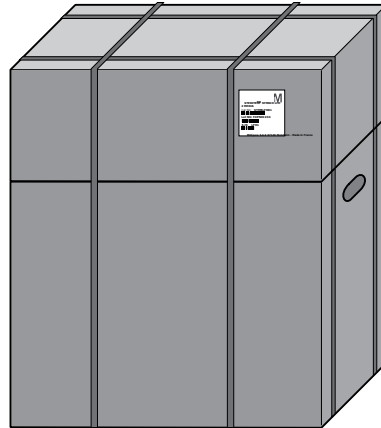

The larger box contains:

- Steritest™ Symbio Pump
- Communication hub
- Pump Certificate of Quality
- Operator and equipment safety instructions (in ten languages)
- 2 Steritest™ canisters carrying trays
- User quick guide for the Steritest™ canisters carrying trays and rack

### **WARNING**

Do not discard the Steritest™ canisters carrying trays. Deliver them to the final user of the pump.

The smaller box contains the pump accessories:

- Bottle holder (support rod and basket, not assembled)
- Drain tray (support and container, not assembled)
- 2 threaded stems
- Silicone drain tubing (1.5 meter)
- Network cable
- Power cord
- A USB flash drive



- Quick guides (in German, English, Spanish, French, Italian, Portuguese, Japanese, Simplified Chinese, Russian, and Turkish):
  - Steritest™ Symbio Pump Startup Quick Guide
  - Steritest™ Symbio Pump User Interface Quick Guide
  - Steritest™ Symbio Software Quick Guide

To unpack the boxes:

1. Using the carrying handles on the larger box, place the package on a flat, stable, and horizontal surface.
2. Cut the plastic straps to separate the two boxes.
3. Put the smaller box aside.
4. Open the larger box.
5. Retrieve the pump Certificate of Quality and the safety instructions.
6. Remove the communication hub from the top wedging system.
7. Remove the top wedging system.
8. Place hands below the pump, take it out of the box, and place it on a flat and stable surface.
9. Remove the 2 Steritest™ canisters carrying trays and deliver them to the user of the pump.

#### **NOTE**

Store all packaging materials in a dry area for future use. The pump and the communication hub must be packaged in this certified packaging if shipment back to a service center is required. The pump and the communication hub can also be packaged in the Steritest™ Symbio pumps shipment case (see [Accessories and Replacement Parts](#)).

The top wedging system is also required for use in pump installation (see [Installing the Pump](#)).

10. Open the smaller box that contains the accessories.



11. Remove the power cord from the smaller box.

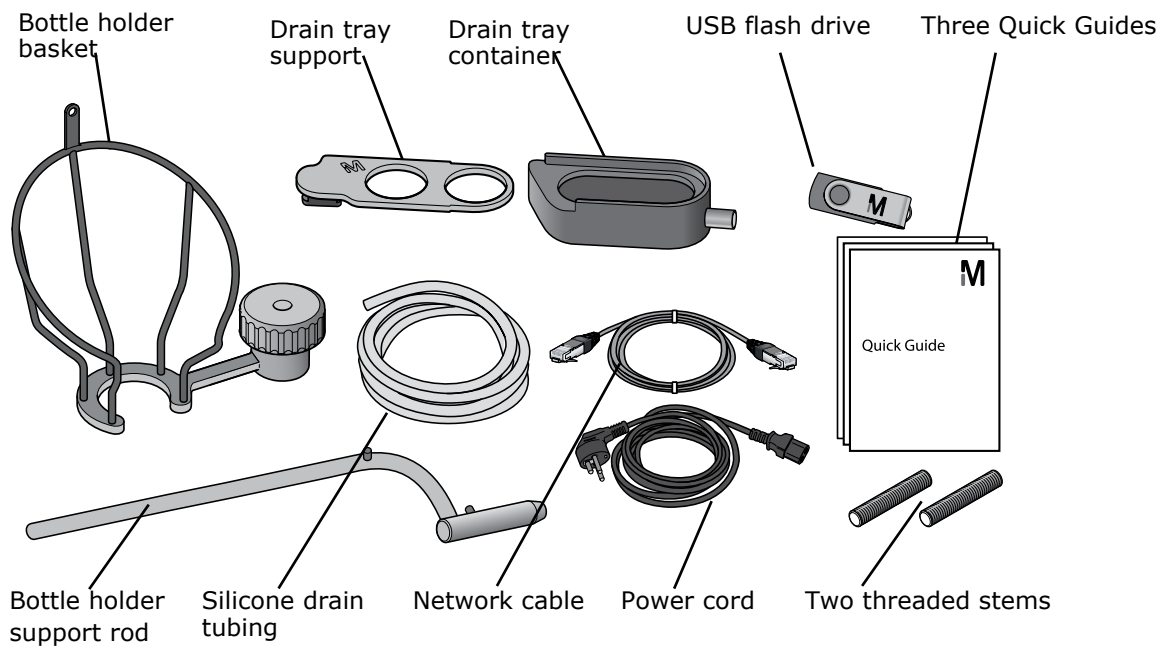

**NOTE**

The Steritest™ Symbio Pumps User Guide, this installation guide for the ISL pump version, and the Steritest™ Symbio Software User Guide are available at [www.millipore.com/steritest-symbio](http://www.millipore.com/steritest-symbio).

## Verifying that the Pump Functions Properly

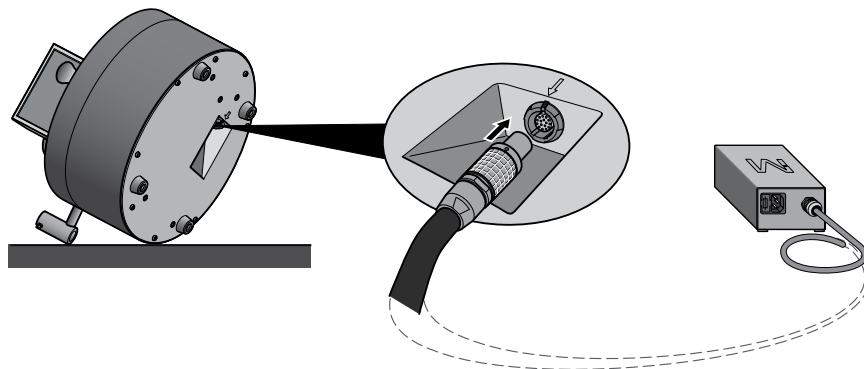

Before installing the pump, verify that it is functioning properly.

1. Place the pump on its side and connect the communication hub pump connection cord to the pump power inlet.

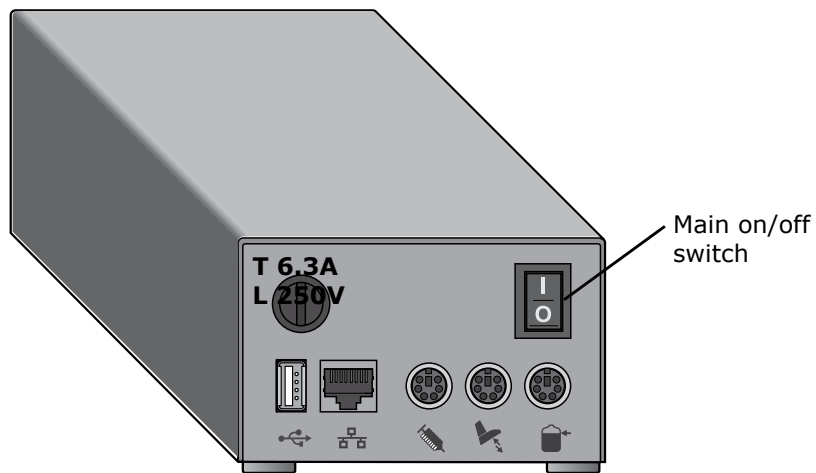

2. Connect the communication hub to the power source using the power cord delivered with the pump.
3. Switch on the communication hub by pressing the on/off switch (position I ).



4. Simultaneously press and hold the pump on/off  and the open/close  buttons. The screen displays the range of Steritest™ devices. This is followed by the welcome screen:



5. After a few seconds, the following screen displays:

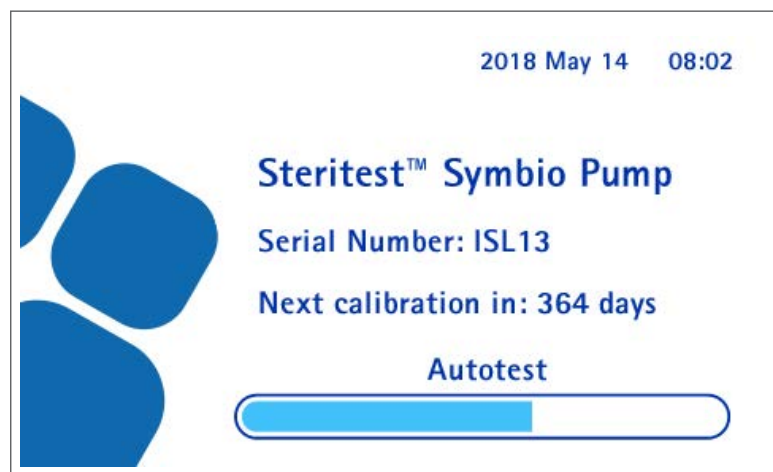



6. When the autotest is complete, the following screen displays. A ✓ symbol in a check box indicates that an accessory or data source is connected to the communication hub.

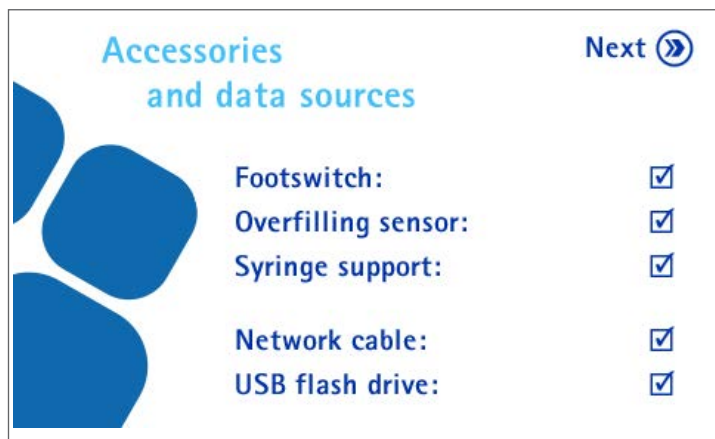

7. Press the » button. The installation menu displays.

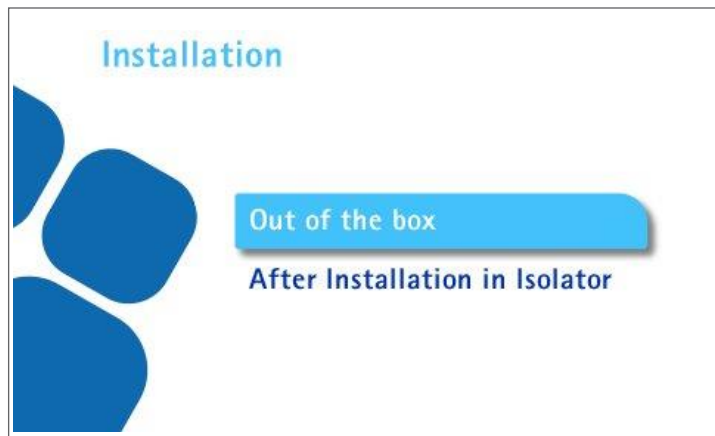

8. Press the control knob to select **Out of the box**. The Out of the box screen displays.

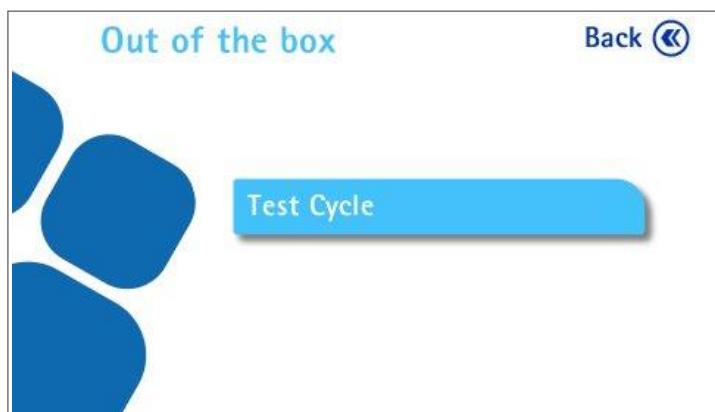

9. Press the control knob to begin the test cycle. Only one cycle will be performed.

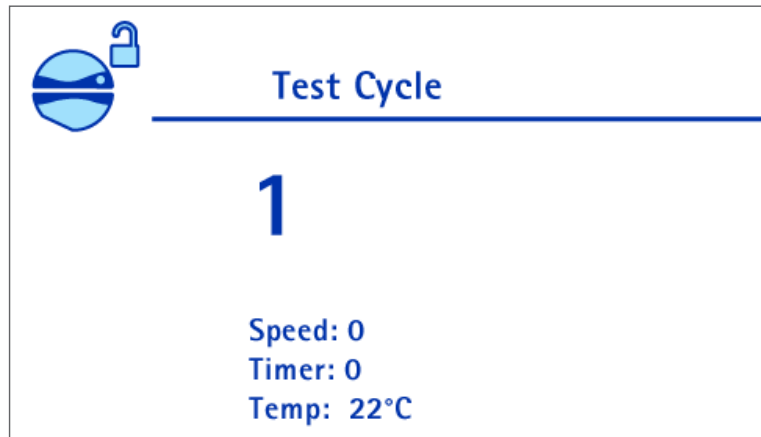

10. After the pump head closes, the pump starts automatically, and 1 test cycle is performed.

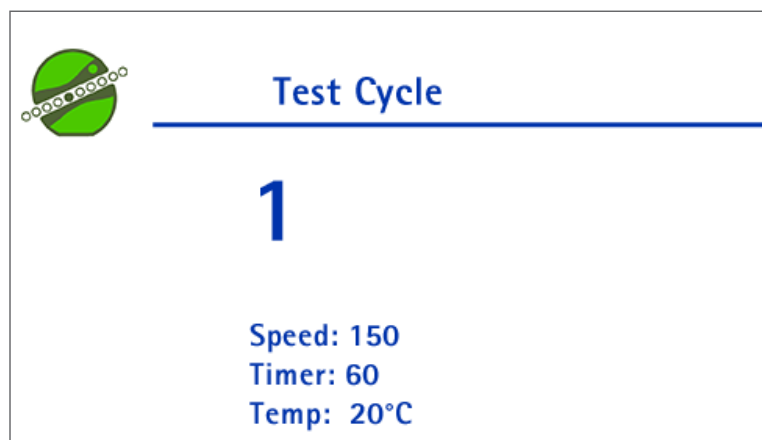

11. When the Test Cycle completes with no error, the following screen displays.

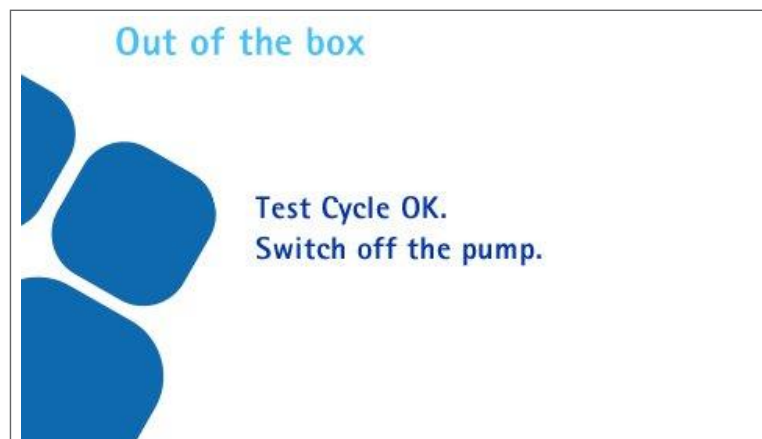

12. Switch off the communication hub by pressing the on/off switch (position O). The Shutdown screen displays.



13. Disconnect the communication hub pump connection cord from the pump power inlet.
14. Proceed to the installation of the pump (see [Installing the Pump](#)).

## Installing the Pump

### NOTE

This procedure applies to isolator tables that are up to 7 mm thick. For thicker isolator tables, an adaptation kit is required. Contact our sales representative for more information.

1. Verify that the pump functions properly, and verify that the pump head is in its closed position (see [Verifying that the Pump Functions Properly](#)).
2. Retrieve the top wedging system from the packaging materials and place it on a flat, stable horizontal surface with the face in which the communication hub was located against the surface.
3. Turn the pump display to its transportation position (horizontal).
4. Turn the pump up side down and place it on the top wedging system.

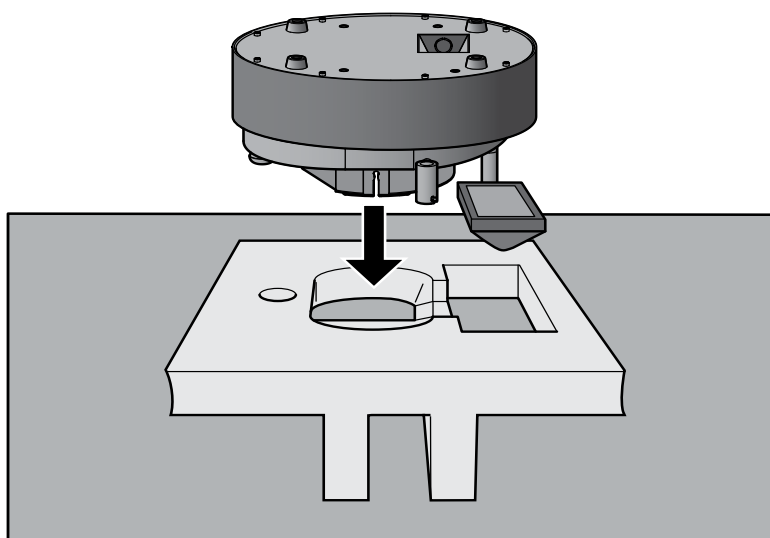

5. Locate the 8 screws that secure the pump bottom plate to the pump.

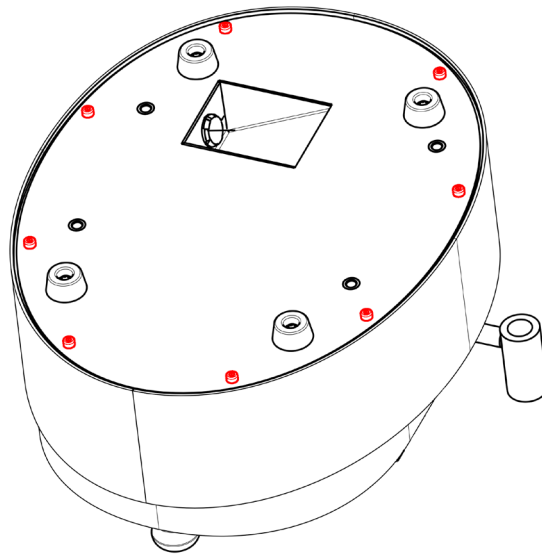

6. Use a T20 star screwdriver to remove the 8 screws.

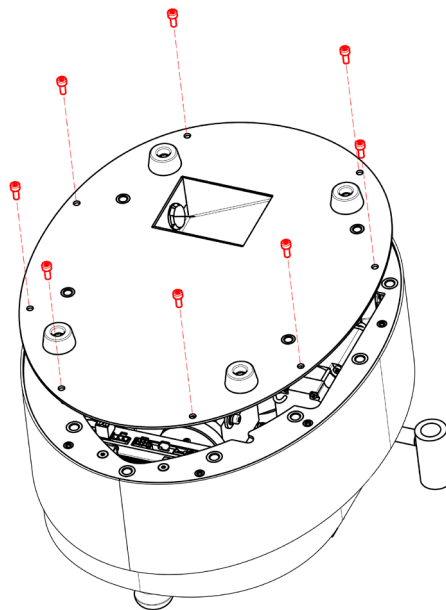

**NOTE**

The cable that connects the pump power inlet to the electronic board is attached to the pump bottom plate. It must be disconnected in order to remove the pump bottom plate.



7. Gently lift the pump bottom plate off the pump (1), disconnect the cable (2), and completely remove the bottom plate (3).

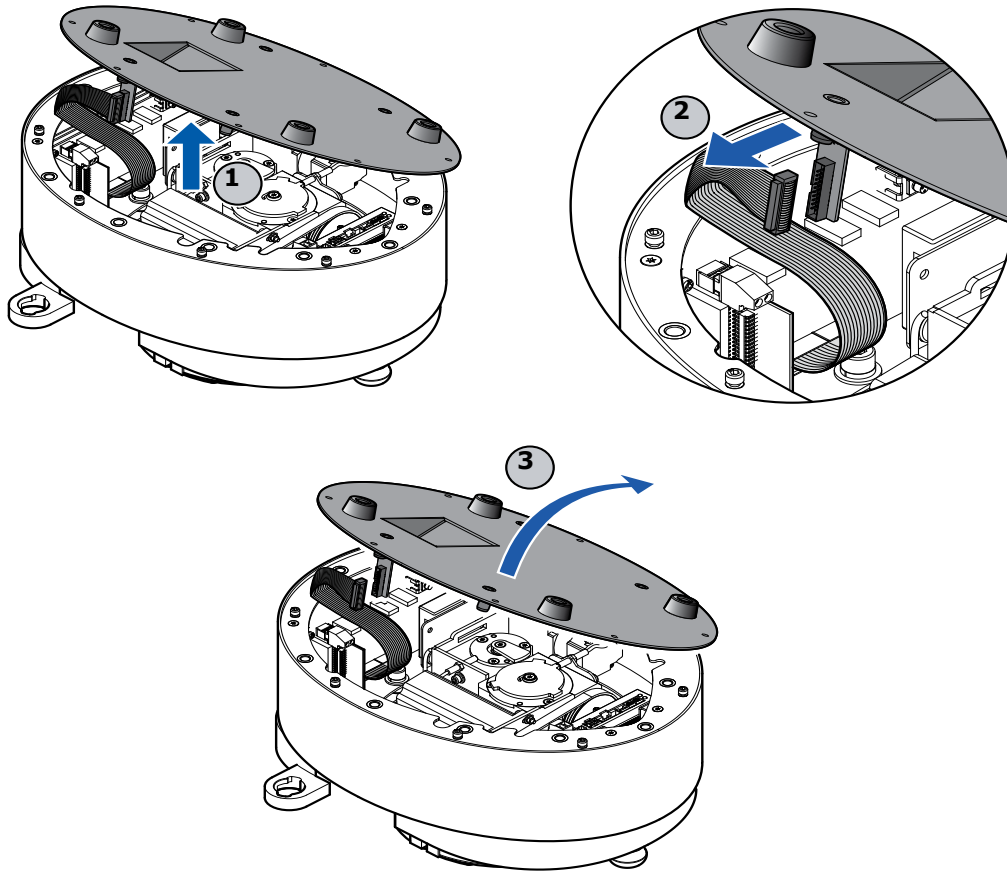

8. Locate the main component of the pump and all the cables from the electronic board (located at the rear of the pump) and the cables from the rotor motor reducer driver (located at the front of the pump).

**NOTE**

In the following illustrations, the cables are not represented in order to simplify the drawings.

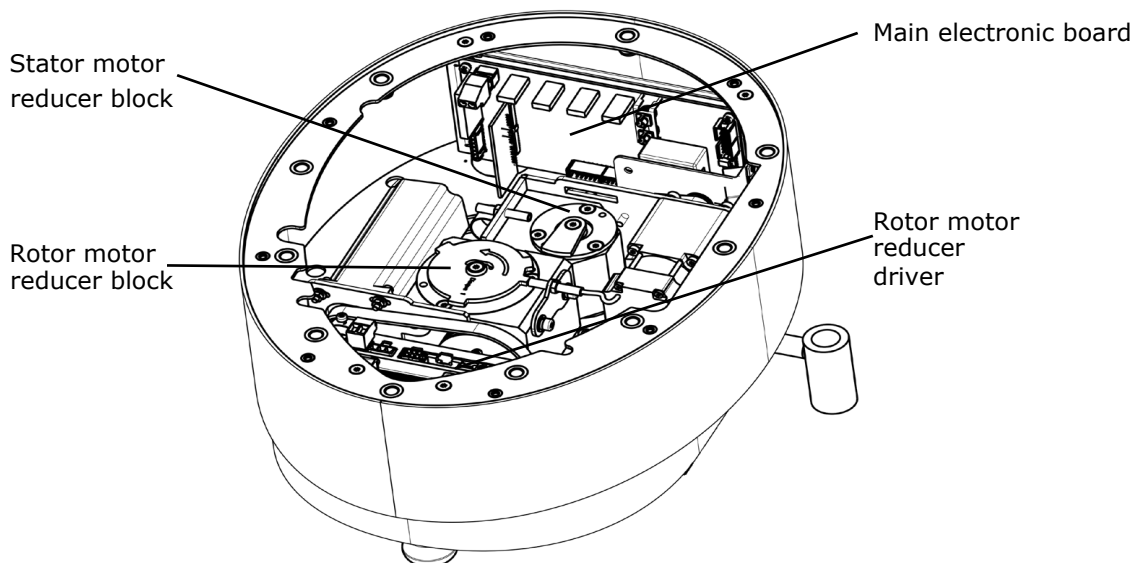

Electronic board simplified view:

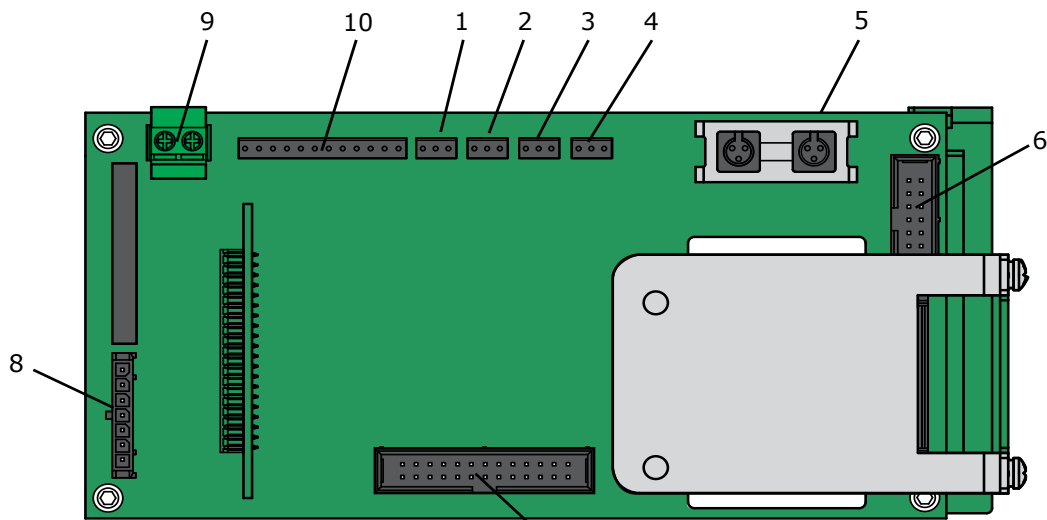

Rotor motor reducer driver view:

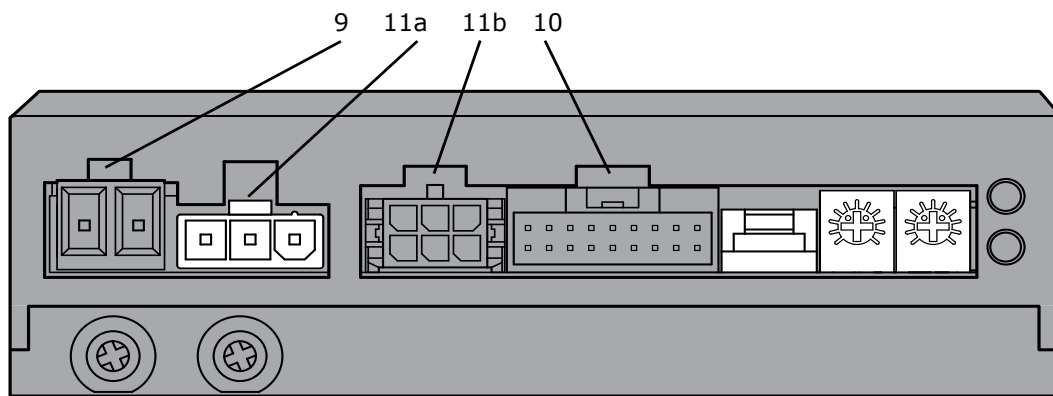

9. Disconnect the 3-pin connector (11a) and the 6-pin connector (11b) from the rotor motor reducer driver.
10. Locate the cable holder that is attached to the pump housing at the right of the electronic board. Gently pull this cable holder and release the cables.



11. Disconnect the cables 3 and 4 from the main electronic board (see [Electronic board simplified view](#)).

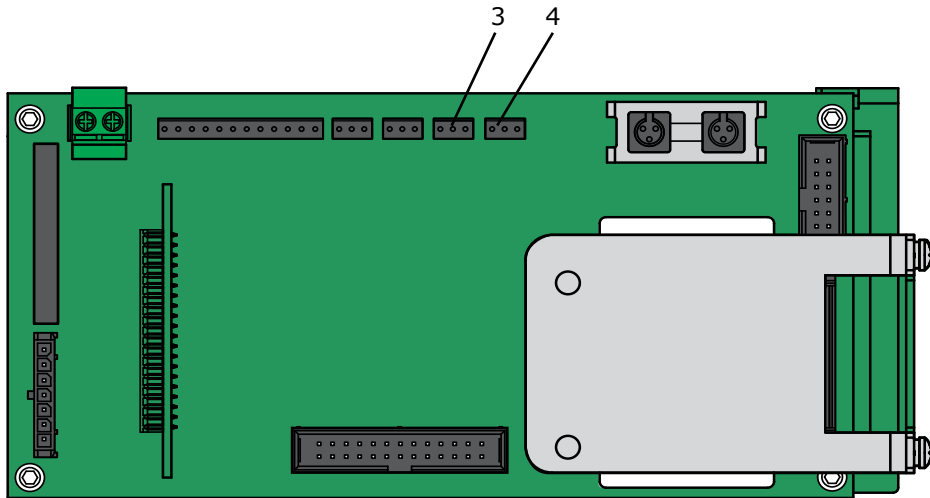

12. Locate the 3 screws on the rotor motor reducer block that secure the block to the pump.

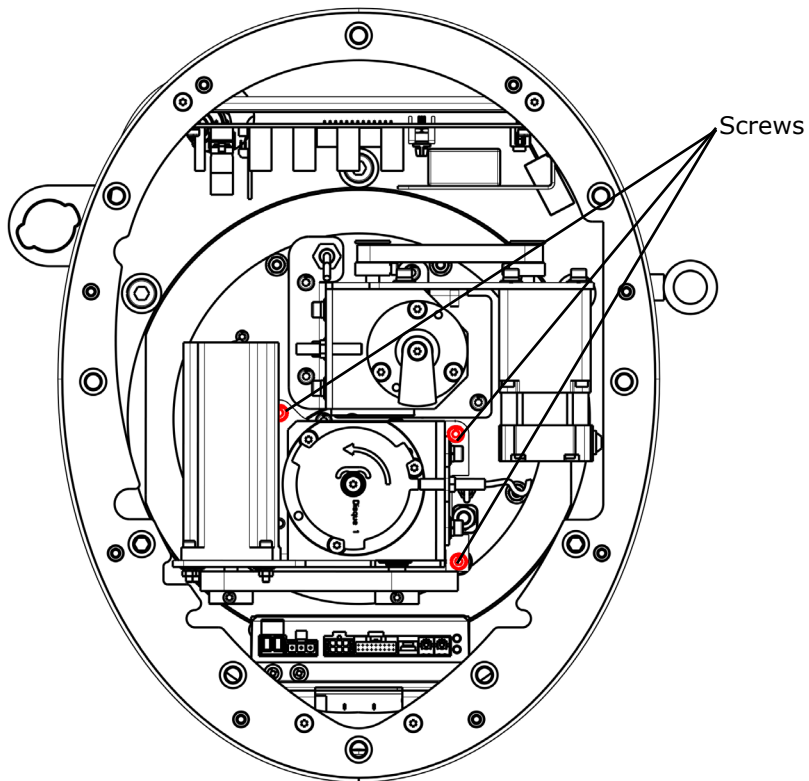

13. Use a #3 hex key to unscrew and remove the 3 screws and washers.
14. Remove the rotor motor reducer block from the pump.

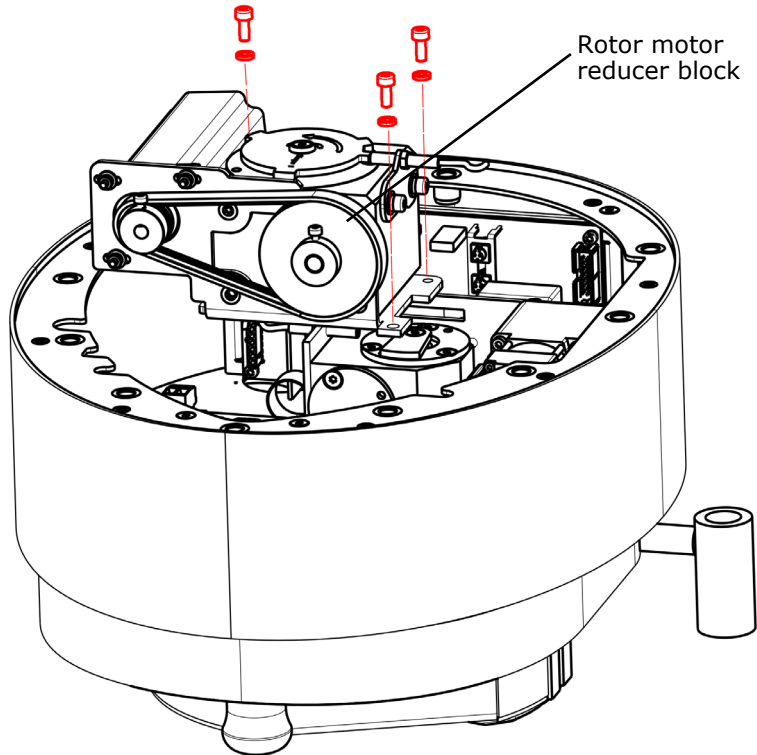

**NOTE**

To facilitate the installation in the isolator, do not modify the position of the rotor motor reducer belt.

15. Locate the cable holder attached to the pump housing.

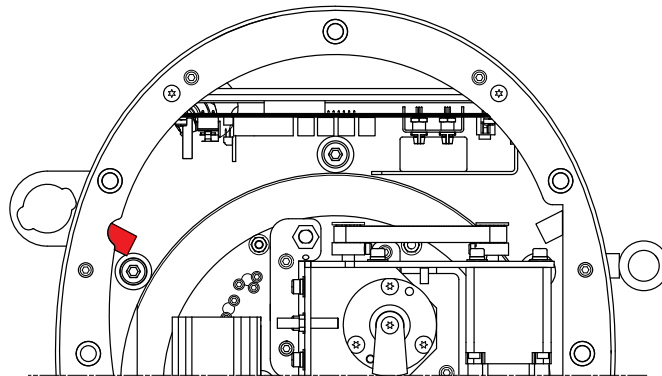



16. Gently pull this cable holder and release the cables.
17. Disconnect cables 1, 2, and 8 from the main electronic board.

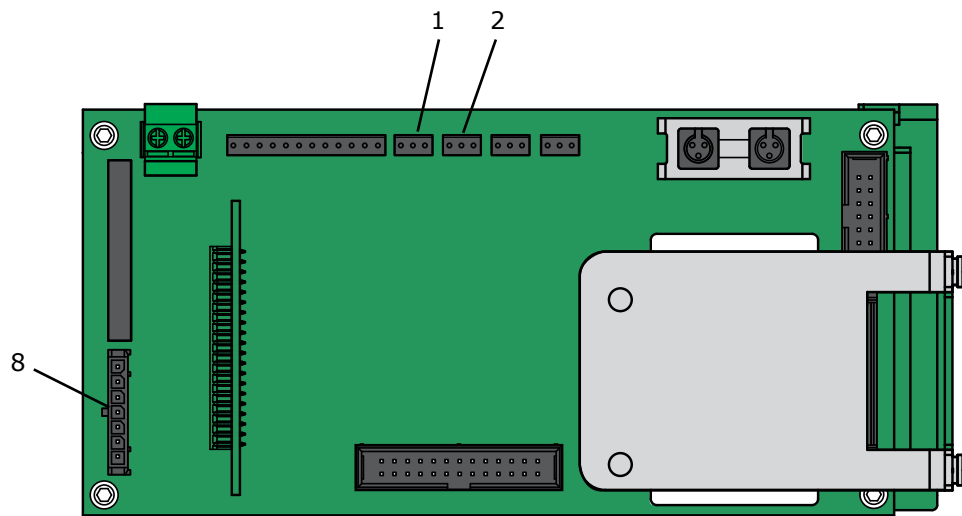

18. Locate the 4 screws on the stator motor reducer block that secure it to the pump (see illustration above).
19. Use a #3 hex key to unscrew and remove the 4 screws and washers.
20. Remove the stator motor reducer block from the pump.

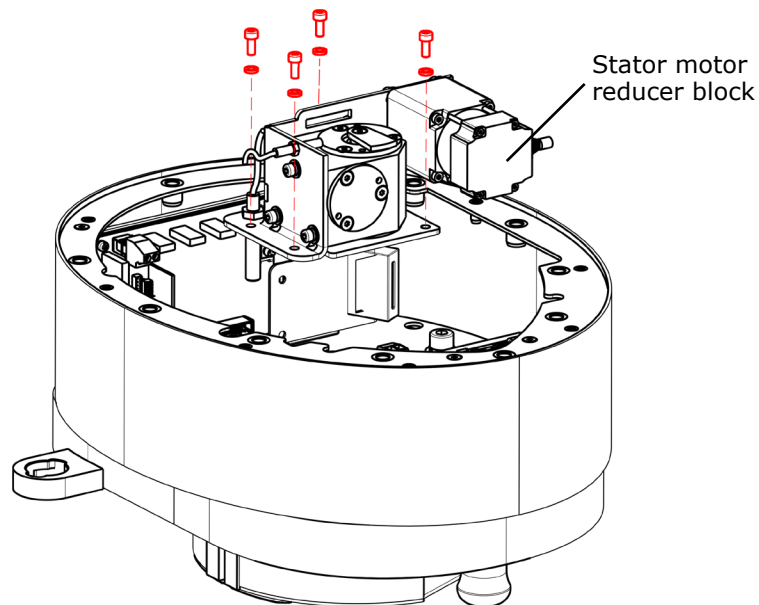

**NOTE**

To facilitate the installation in the isolator, do not modify the position of the stator motor reducer belt.

- 21. Disconnect cables 5, 6, 9, and 10 from the main electronic board (see [Electronic board simplified view](#)).

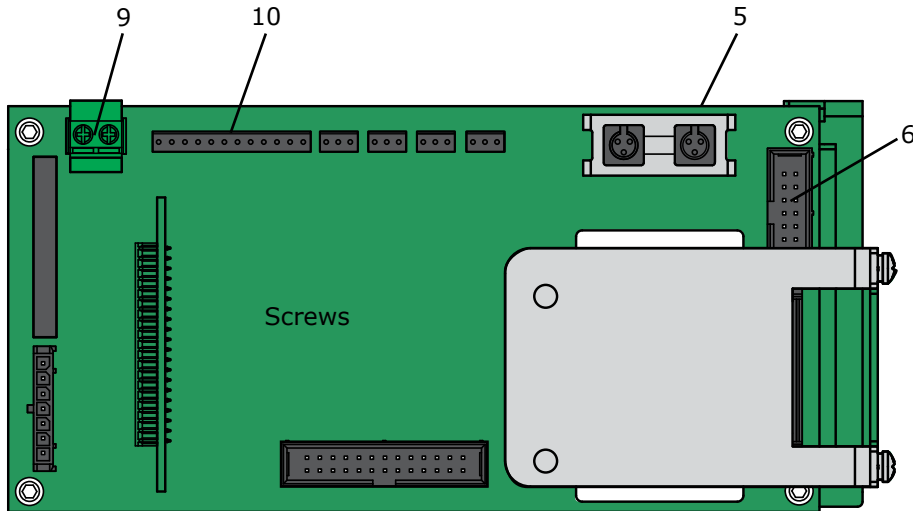

- 22. Locate the 5 screws on the pump housing that secure it to the pump.

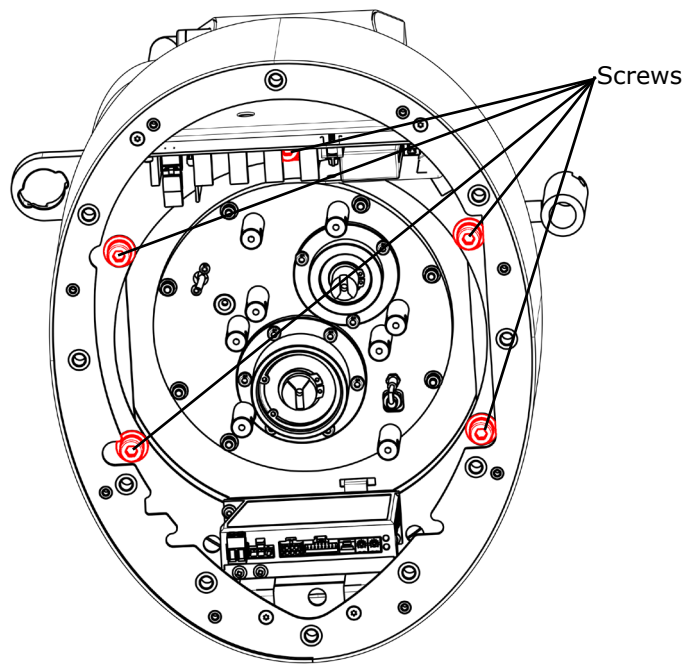

23. Use a #5 hex key to unscrew and remove the 5 screws and washers.

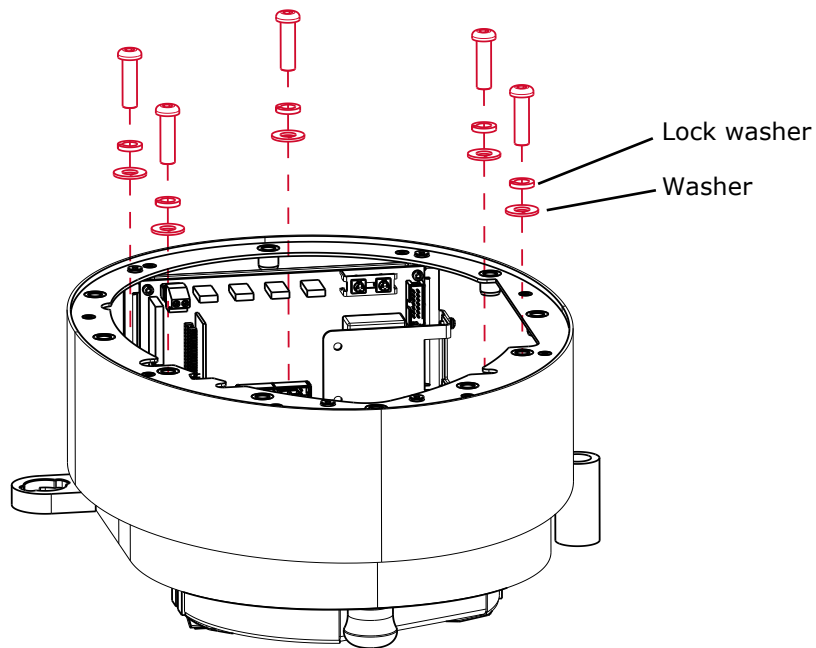

24. Locate the 2 screws that secure the electronic board to the pump housing (see the illustration below).
25. Use a T20 star screwdriver to unscrew the 2 screws.
26. Remove the electronic board from the pump housing. .

**NOTE**

The electronic board remains attached to the pump upper part. Be careful not to damage it.



The electronic board is electrostatic sensitive. Observe precautions for handling.

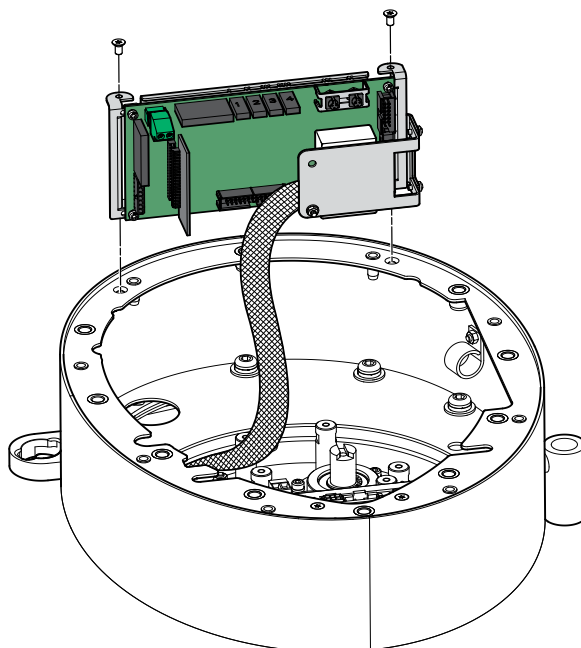

27. Remove the pump housing.

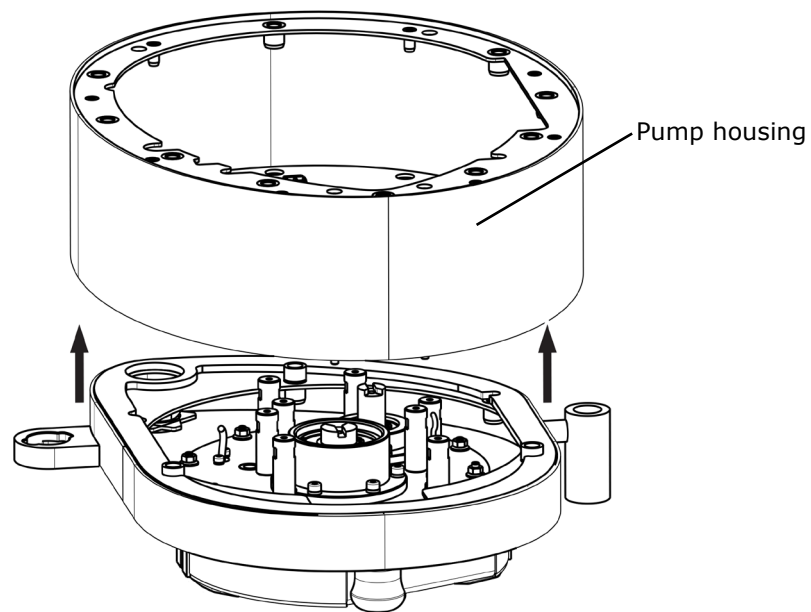

28. Locate and remove the 3 spacers that protect the pump flat seal during storage and transportation.

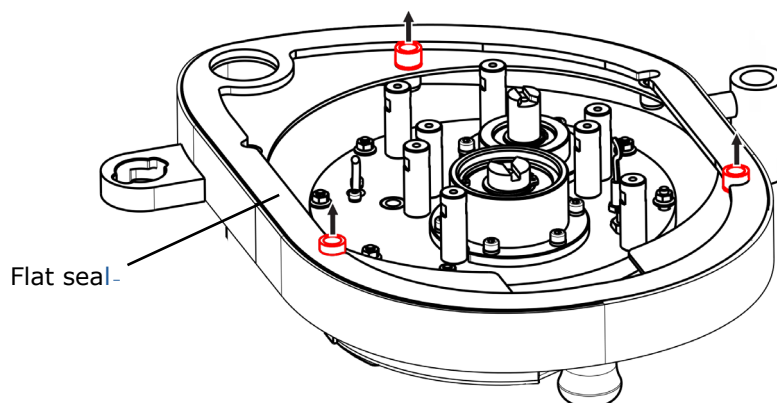

NOTE

Ensure that the flat seal is not damaged. If it is damaged, replace it (see [Accessories and Replacement Parts](#)).



29. Insert the two threaded stems delivered with the pump into the two M8 holes indicated in the following illustration:

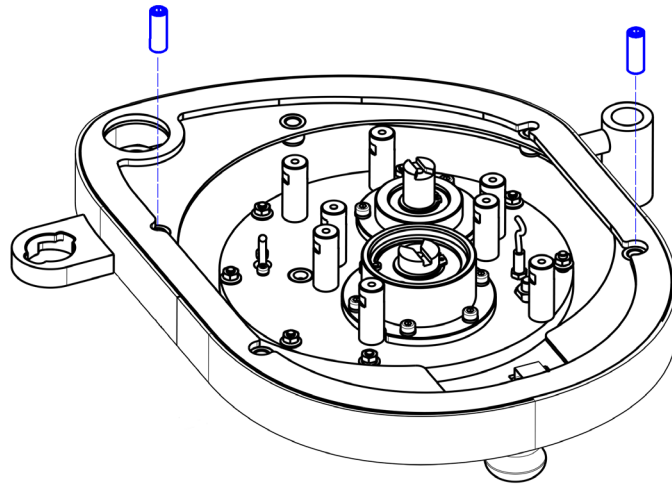

30. Turn the pump upper part right side up and place it above the isolator cutout. Make sure that all the cables and the electronic board go through the cutout.

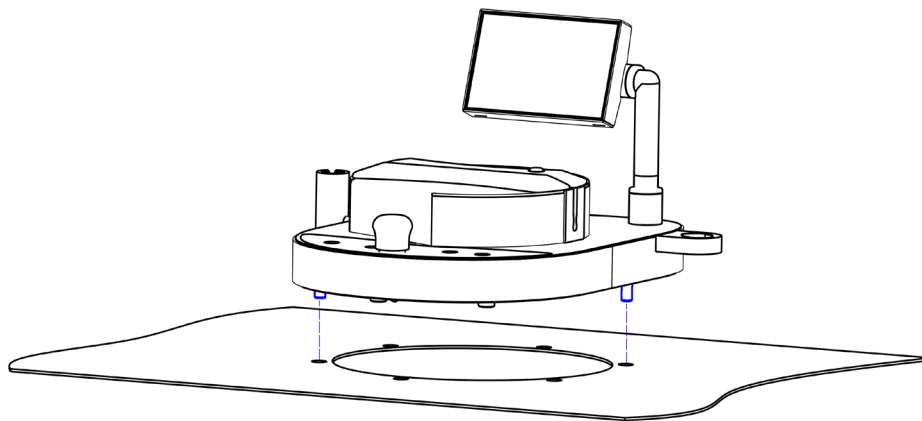

31. Center the pump by placing the two threaded stems in the dedicated holes of the cutout.

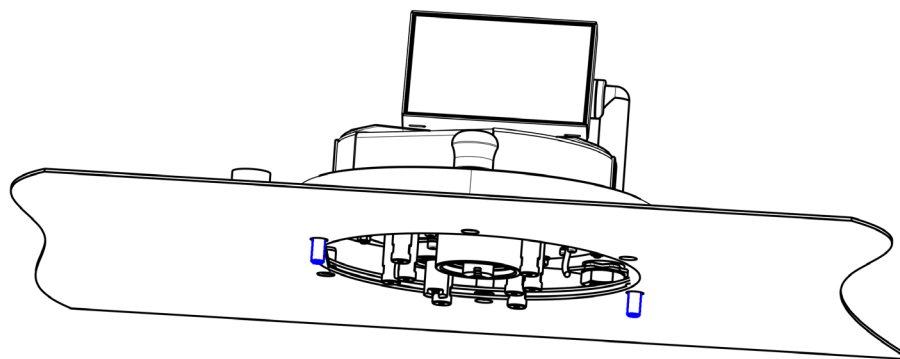

32. Place the pump housing under the isolator table. To center the pump housing, make sure the two threaded stems go through the corresponding pump housing holes, as shown in the illustrations.

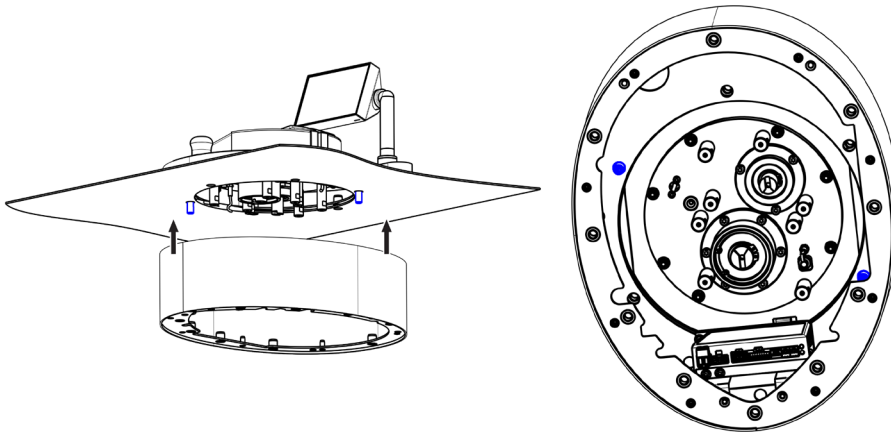

33. While holding the pump housing in place, use a #5 hex key to screw the 2 pump housing screws, with 2 washers each, as shown in the following illustration:

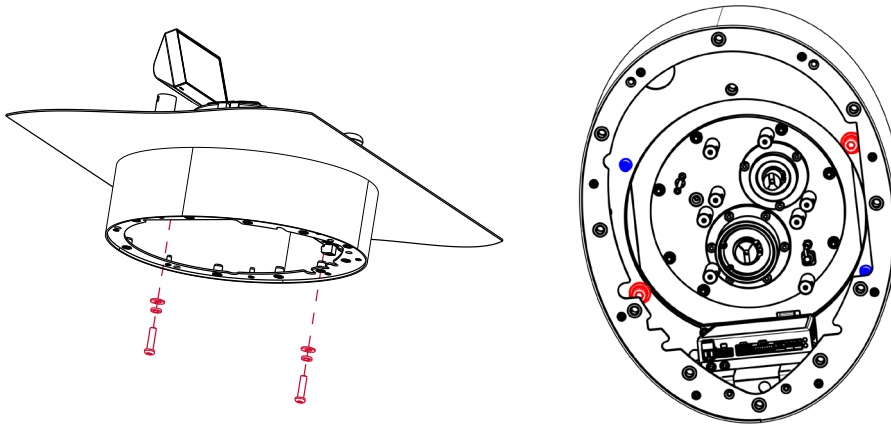

34. Place the electronic board in its housing. Use a T20 star screwdriver to install the two screws that secure it to the pump housing.

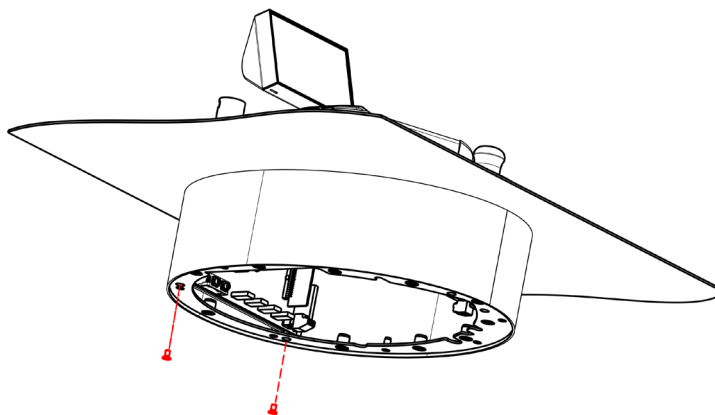

35. Remove the 2 threaded stems.

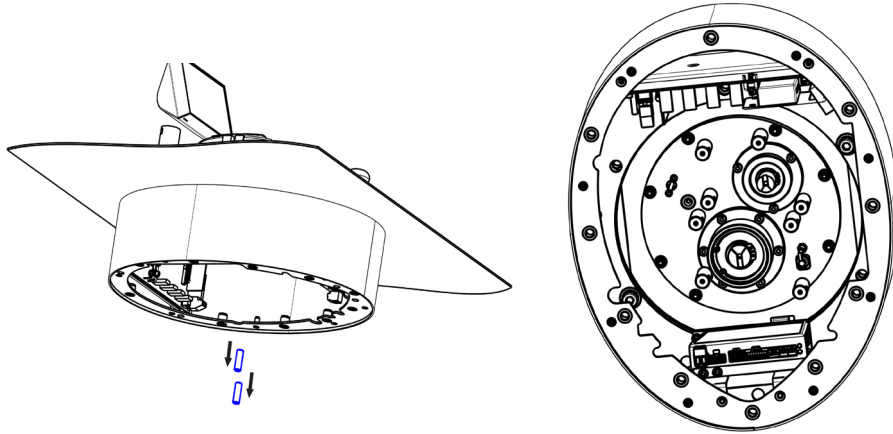

36. Use a #5 hex key to install the 3 other pump housing screws, with washers.

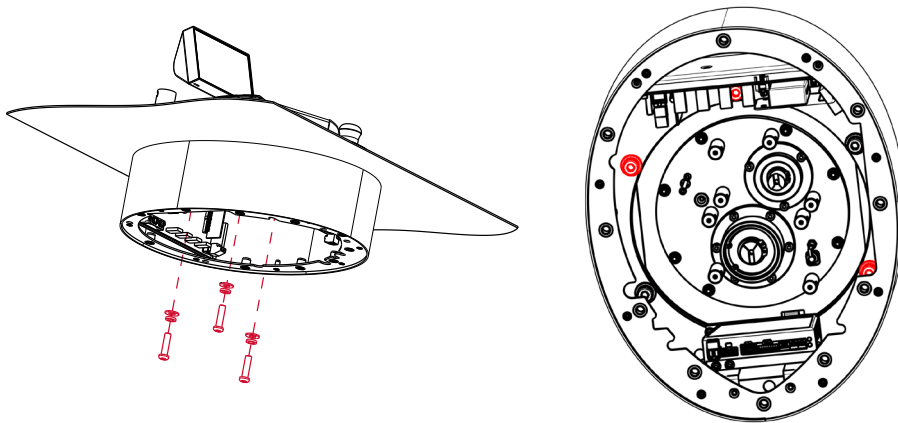

37. Perform a tightness test of the isolator before proceeding.  
If this test fails, ensure that all the 5 screws on the pump housing are properly installed, and ensure that the flat seal is not damaged. If the flat seal is damaged, replace it by a new one (see [Accessories and Replacement Parts](#)).
38. Place the stator motor reducer block in its housing by aligning the coupling pieces located on the stator motor reducer block and at the bottom of the pump upper part.



**NOTE**

Do not turn the coupling piece located at the bottom of the pump upper part. If the position of the stator motor reducer belt has not been modified during the disassembly step, the alignment should be okay. If necessary, turn the stator motor reducer belt to adjust the orientation of the coupling piece located on the stator motor reducer block.

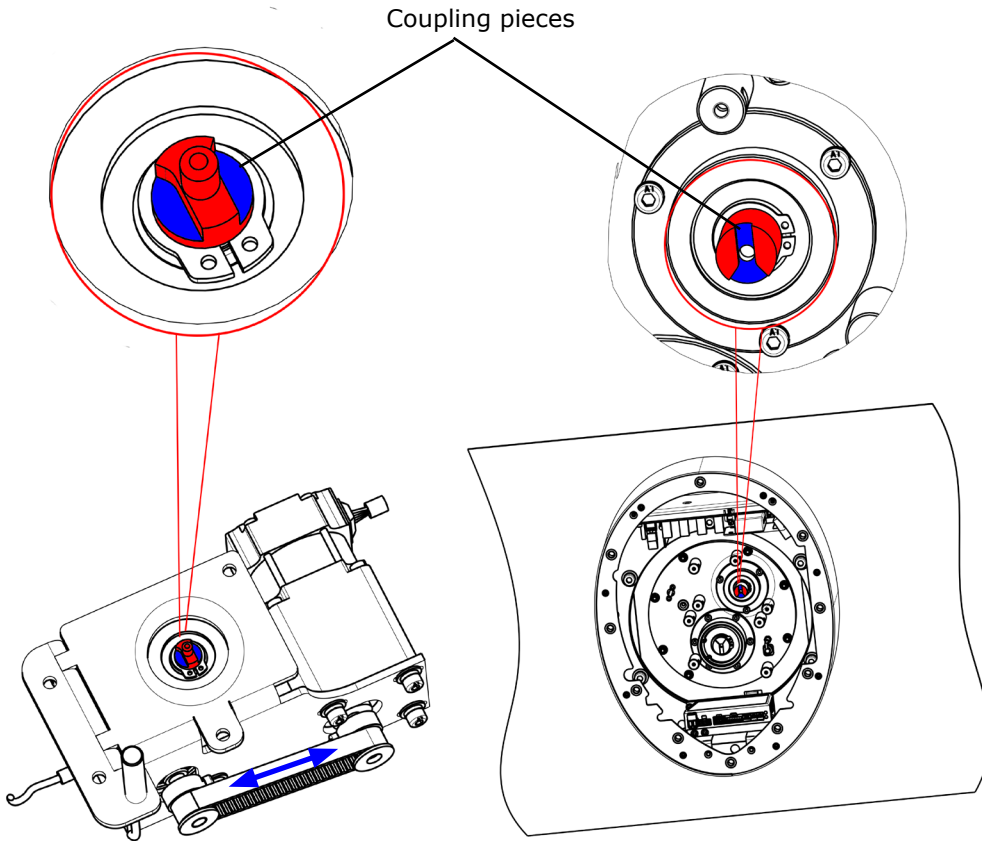

- 39. Use a #3 hex key to install the 4 screws and washers to secure the stator motor reducer block to the bottom of the pump upper part.

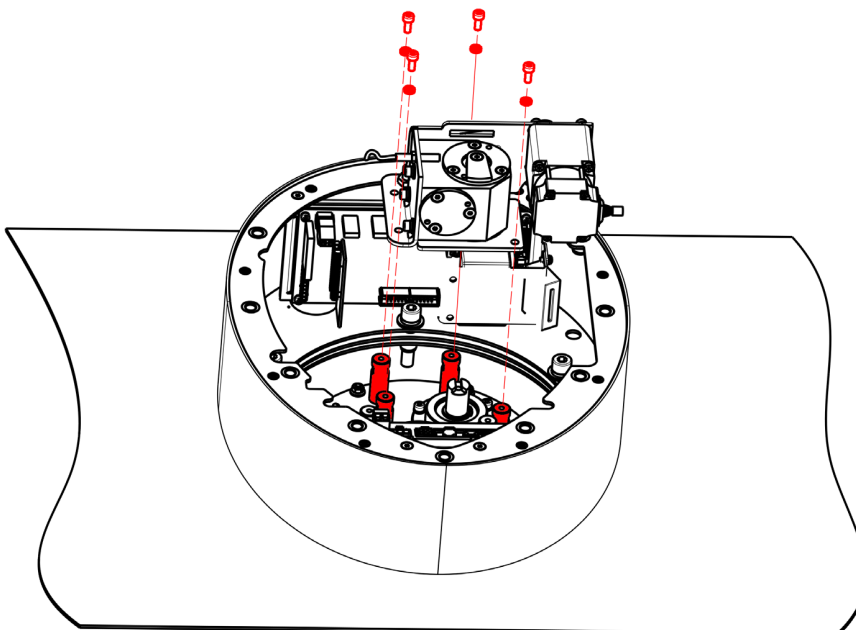



40. Connect cable 1 to the electronic board.

This cable is permanently attached to the pump upper part. It goes through the cable holder attached to the pump housing, and is connected to the electronic board.

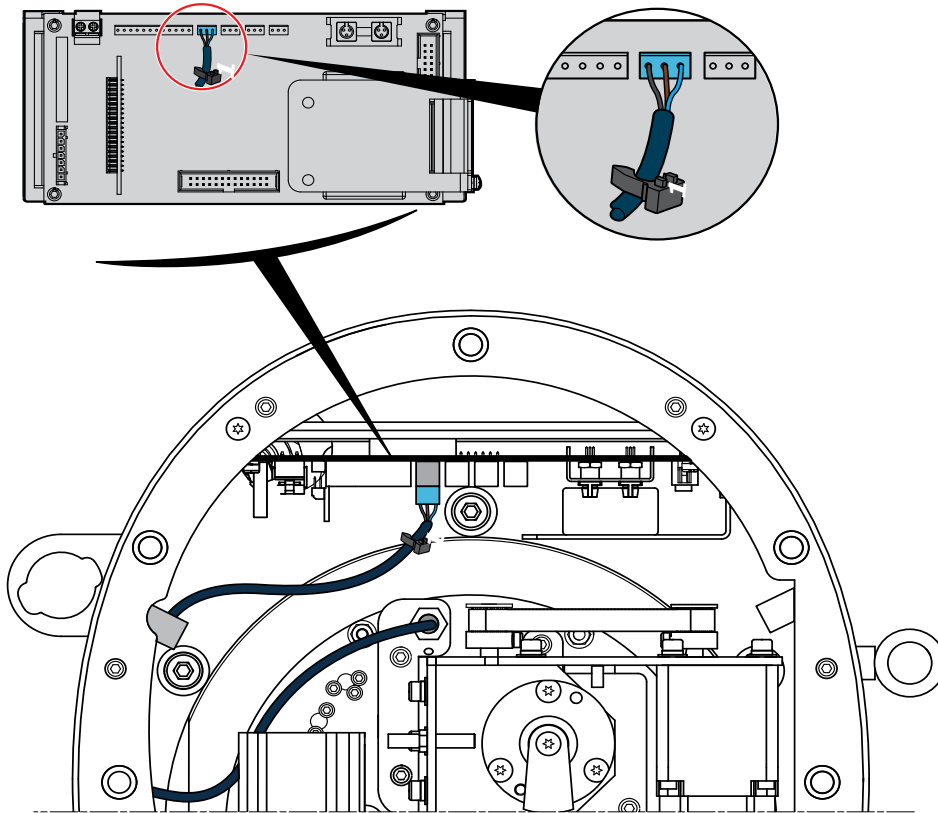

41. Connect cable 2 to the electronic board.

This cable comes from the stator motor reducer block. It goes through the cable holder attached to the pump housing, and is connected to the electronic board.

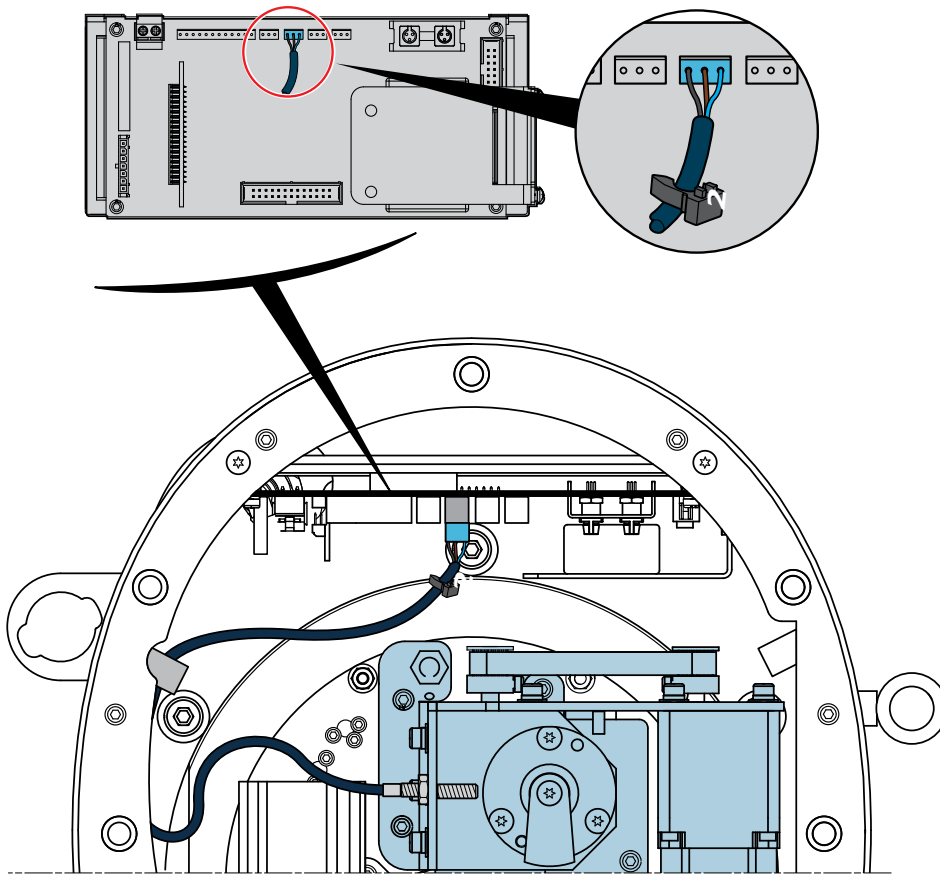

42. Connect cable 8 to the electronic board.

This cable comes from the stator motor reducer block. It goes to the right of this motor reducer block, goes through the cable holder located at the right of the electronic board, then goes behind the electronic board, and is finally connected to the electronic board.

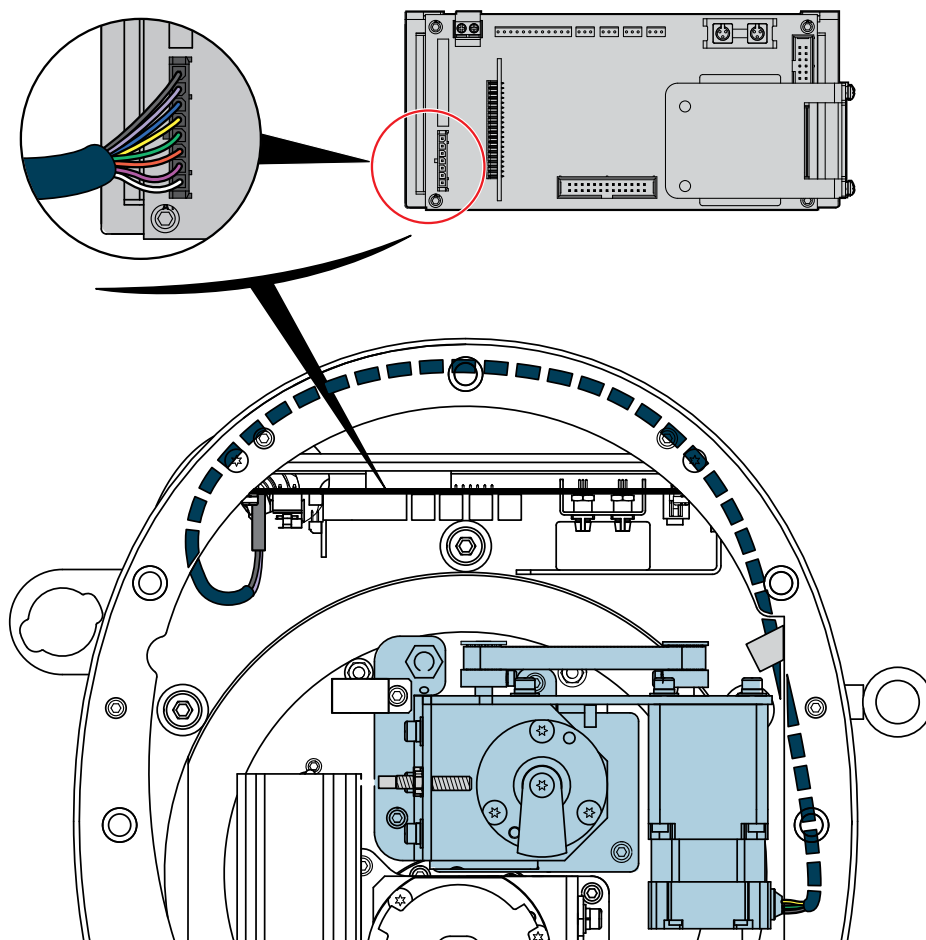

43. Connect cable 5 to the electronic board.

This cable is permanently attached to the pump upper part. It goes through the cable holder attached to the pump housing, and is connected to the electronic board.

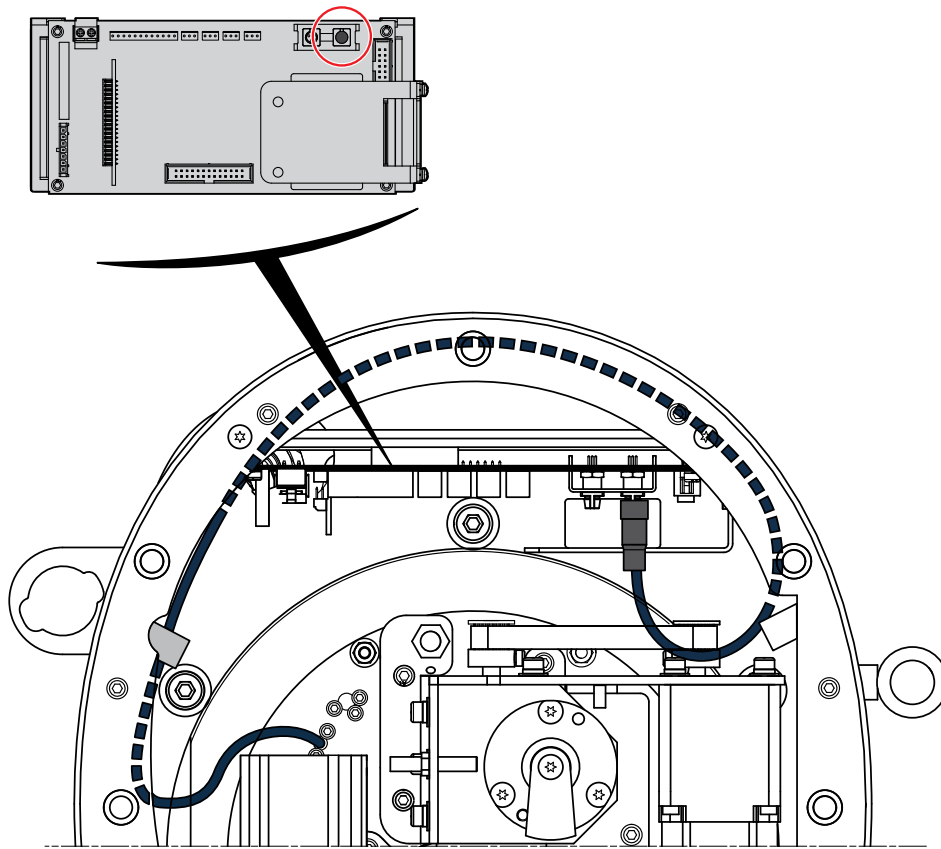

44. Connect cable 6 to the electronic board.

This ribbon cable is permanently attached to the pump upper part. It goes to the right of the stator motor reducer block, goes through the cable holder located at the right of the electronic board, and is connected to the electronic board.

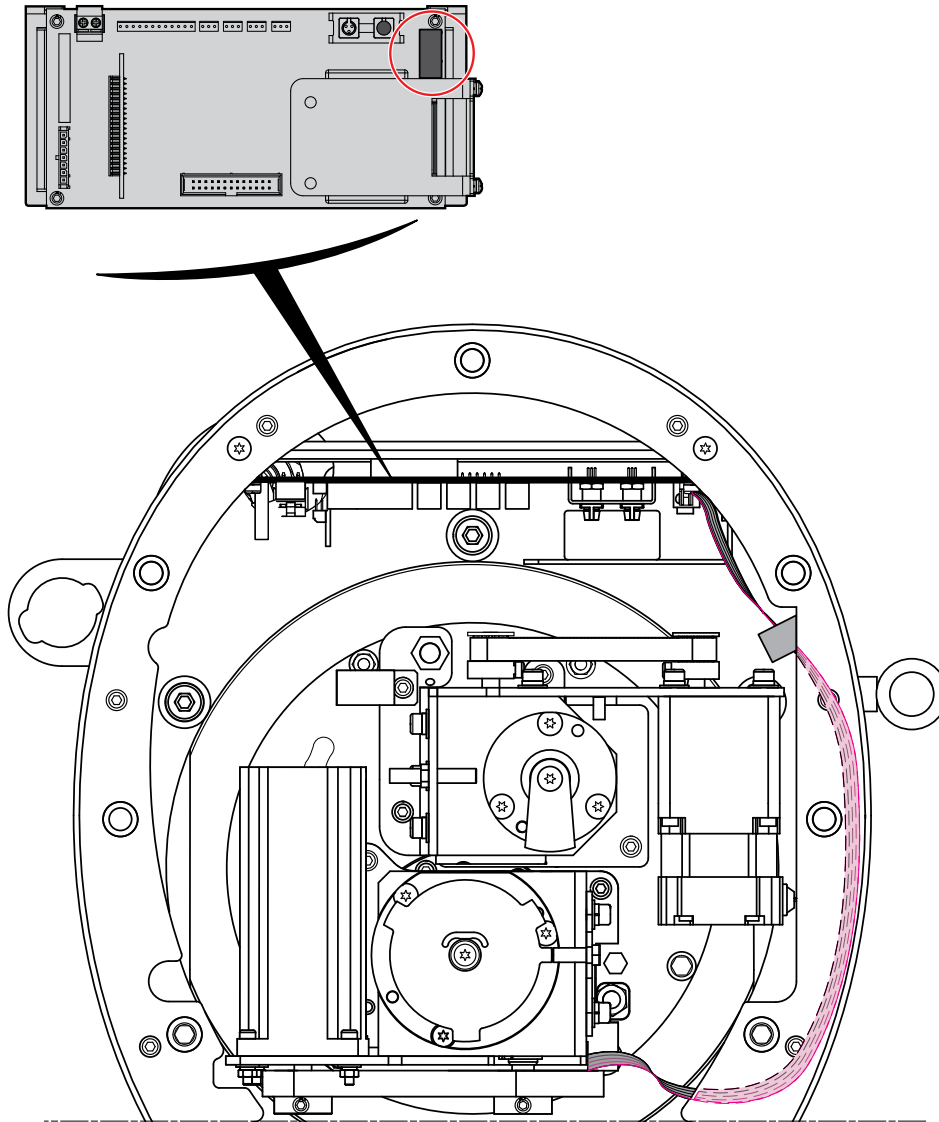

45. Place the rotor motor reducer block in its housing by aligning the coupling pieces located on the rotor motor reducer block and at the bottom of the pump upper part.



NOTE

Do not turn the coupling piece located at the bottom of the pump upper part. If the position of the rotor motor reducer belt has not been modified during the disassembly step, the alignment should be okay. If necessary, turn the rotor motor reducer belt to adjust the orientation of the coupling piece located on the rotor motor reducer block.

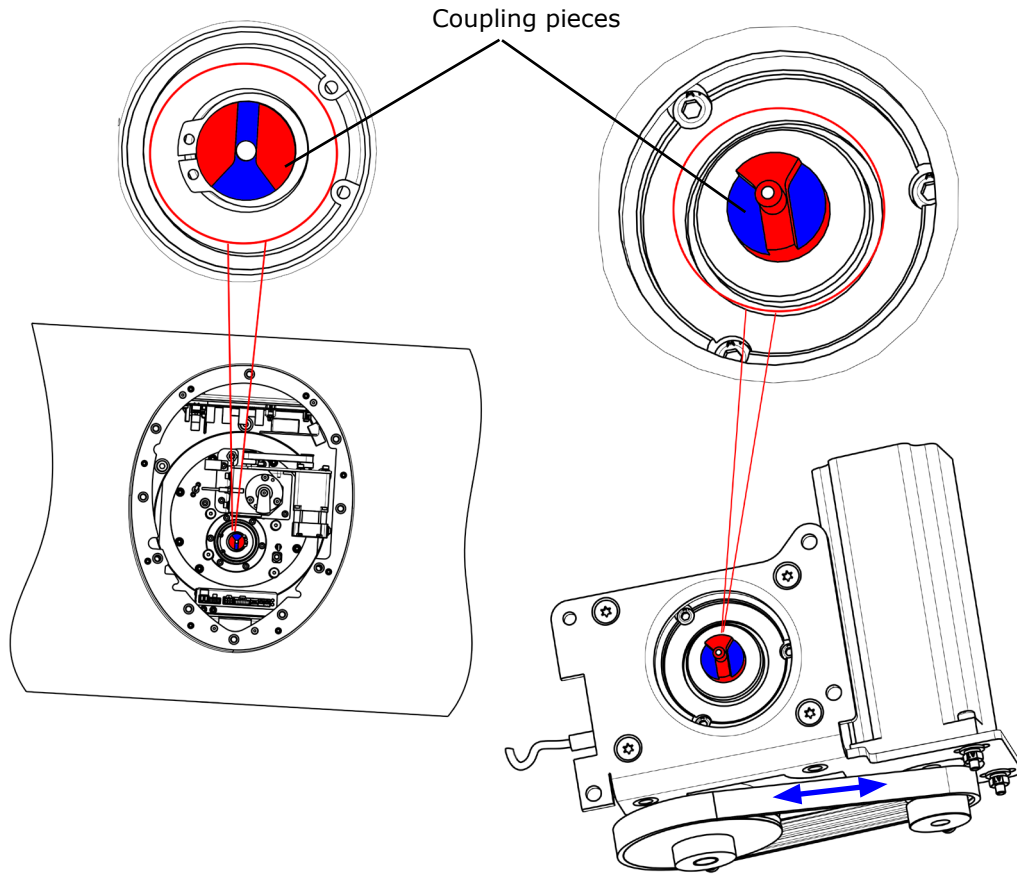

46. Use a #3 hex key to install the 3 screws and washers to secure the rotor motor reducer block to the bottom of the pump upper part.

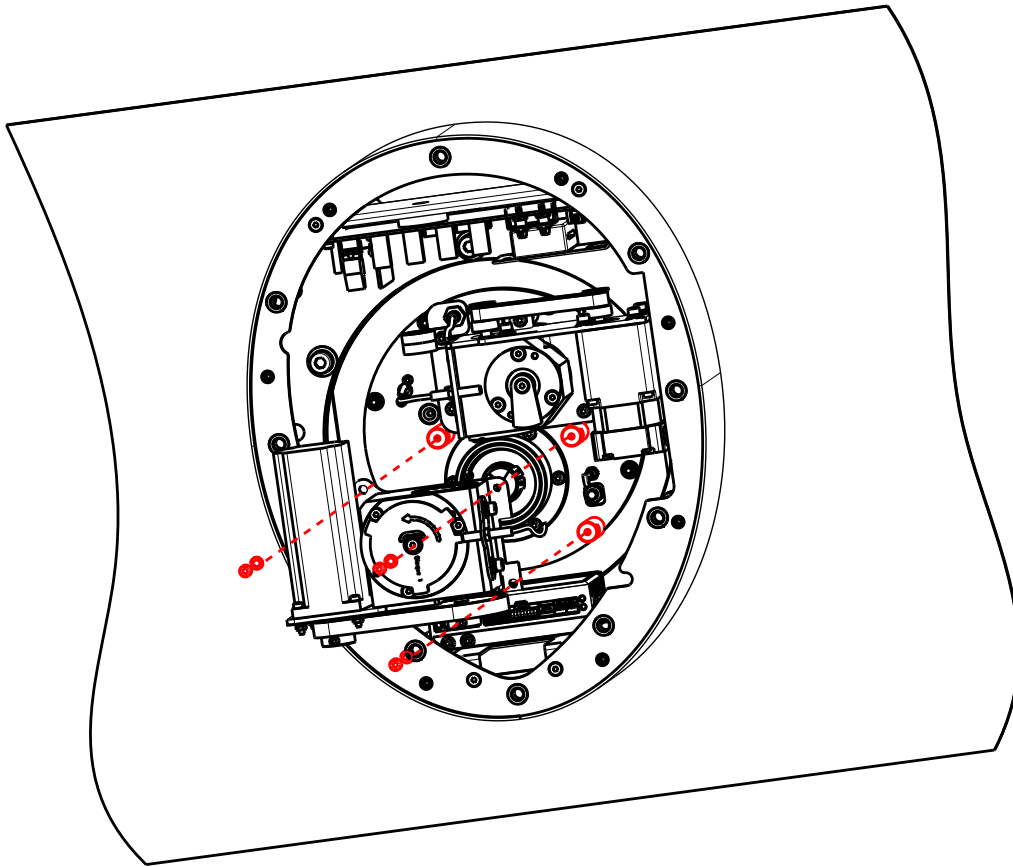

47. Connect cable 9 to the electronic board.

This cable links the rotor motor reducer driver to the electronic board. From the motor reducer driver (2-pin connector), the cable goes behind this rotor motor reducer driver, then to the left of the rotor motor reducer block, then through the cable holder attached to the pump housing, and is connected to the electronic board.

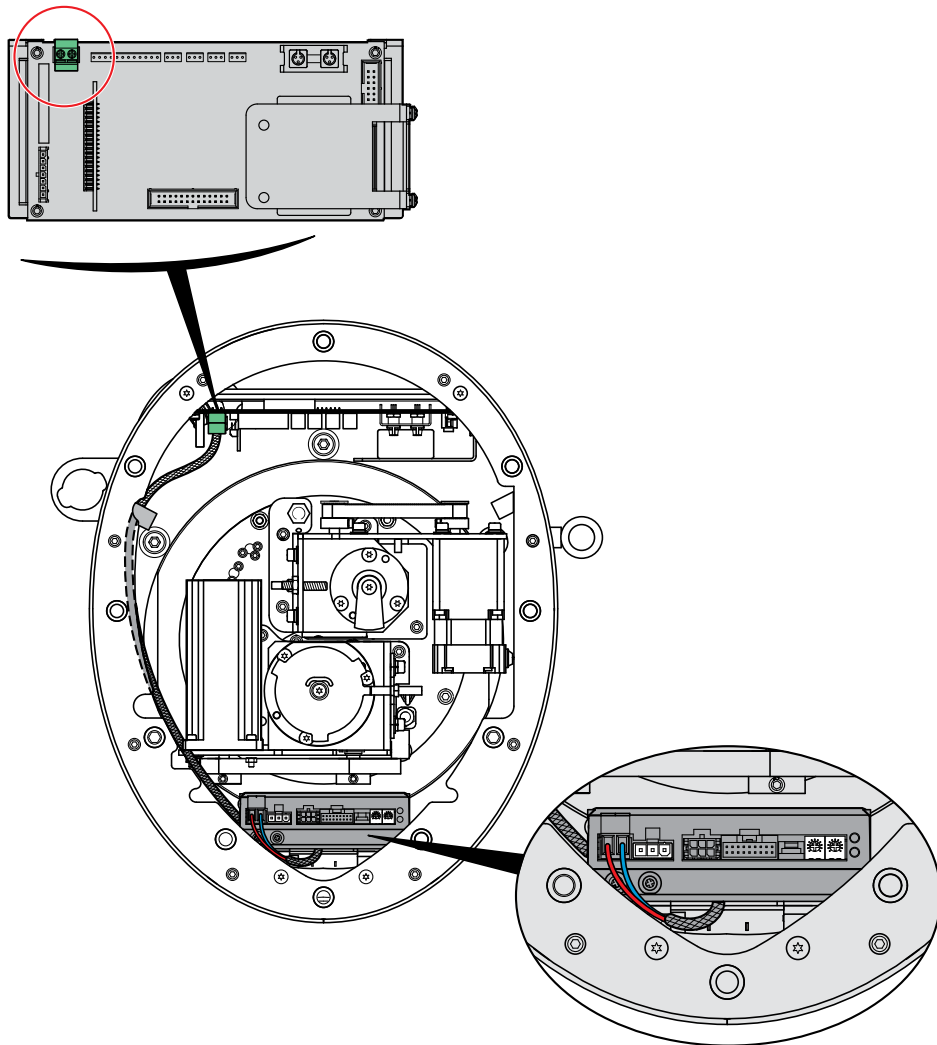



48. Connect cable 10 to the electronic board.

This cable links the rotor motor reducer driver to the electronic board. From the motor reducer driver (18-pin connector), the cable goes behind this rotor motor reducer driver, then to the left of the rotor motor reducer block, then through the cable holder attached to the pump housing, and is connected to the electronic board.

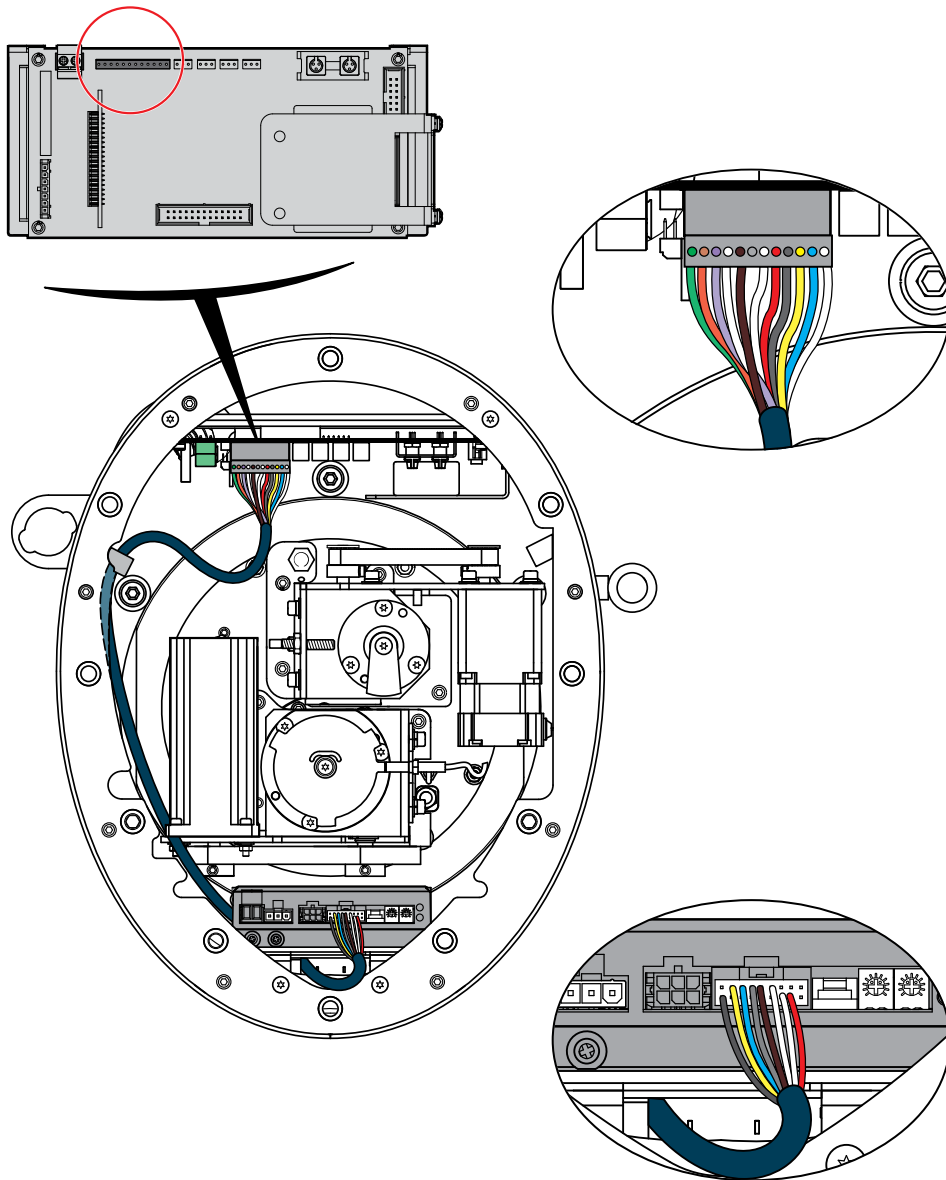

49. Connect the 3-pin connector (11a) and the 6-pin connector (11b) to their bases on the motor reducer driver.

Cable 11 comes from the rotor motor reducer block, goes to the left of this motor reducer block, then goes behind the rotor motor reducer driver to which it is finally connected.

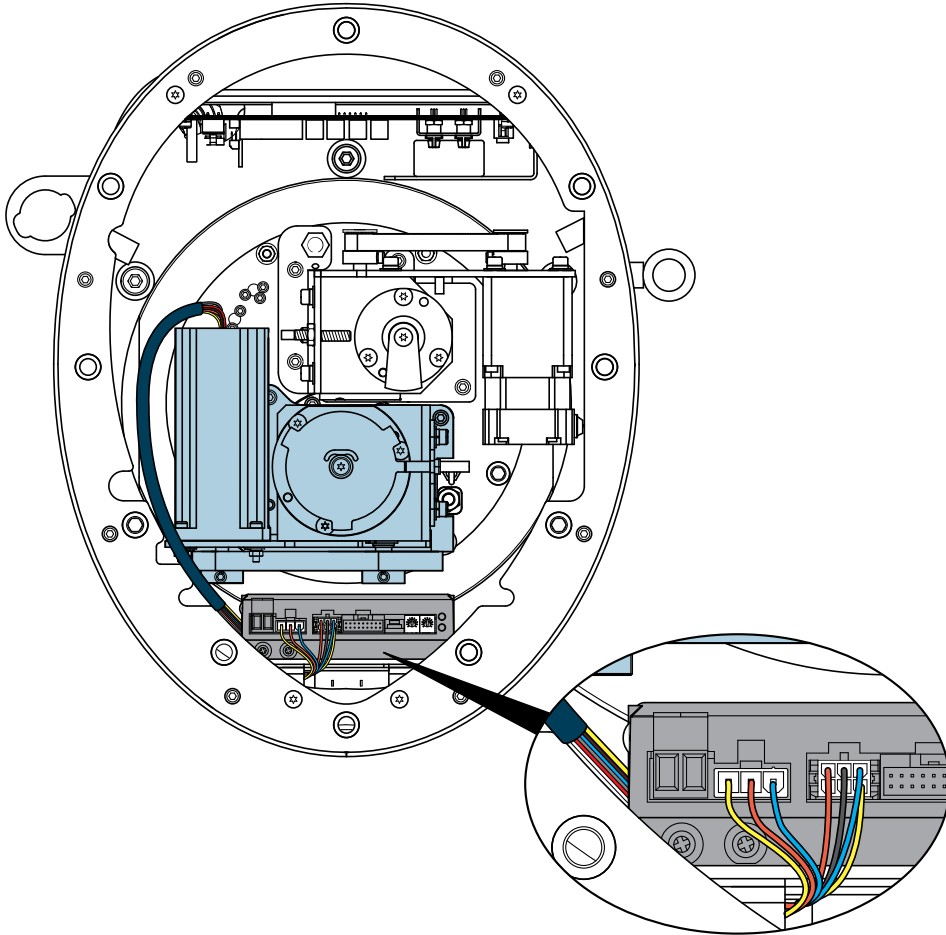

50. Connect cable 3 to the main electronic board.

This cable is permanently attached to the pump upper part. It goes to the right of the stator motor reducer block, then through the cable holder located at the right of the electronic board, and is connected to the electronic board.

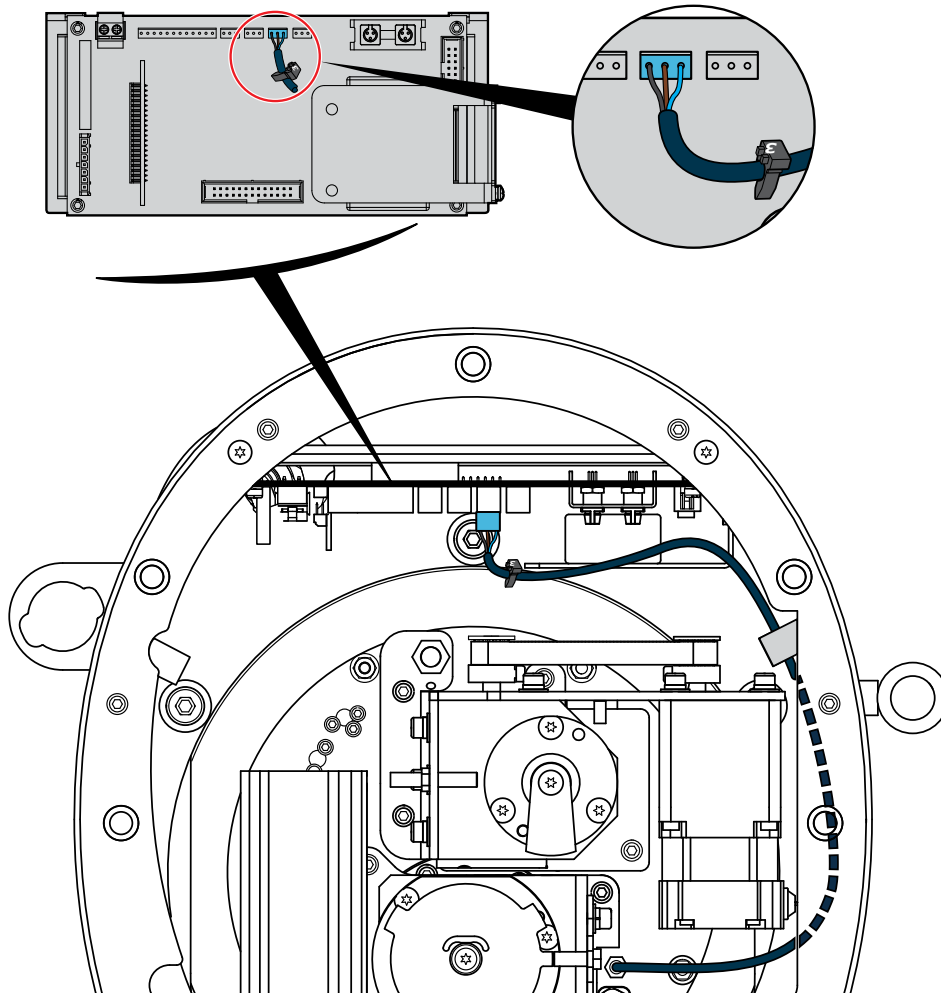

51. Connect cable 4 to the main electronic board.

This cable comes from the rotor motor reducer block, goes to the right of the stator motor reducer block, then through the cable holder located at the right of the electronic board, and is connected to the electronic board.

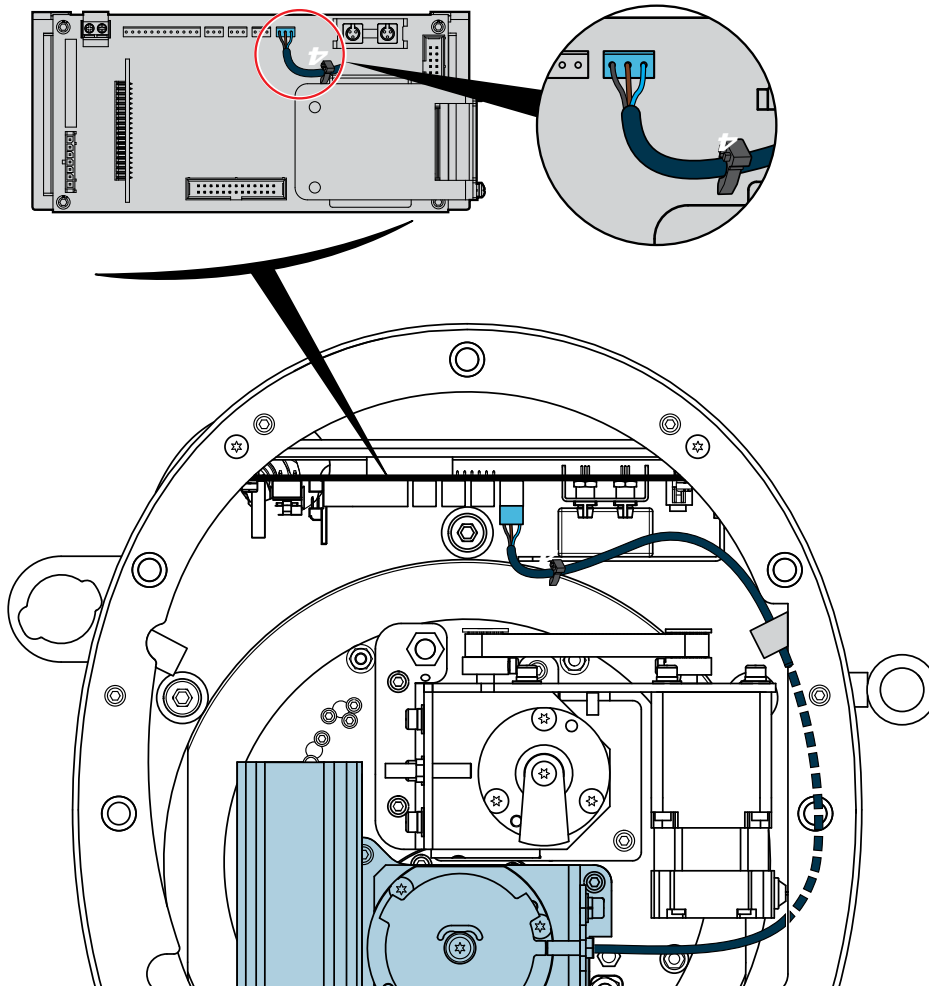

52. Ensure that no cable passes near the belts of the two motor reducer blocks or under the two motor reducer blocks.
53. Position the pump bottom plate underneath the pump housing.



54. Connect the power connector cable to the power connector located on the pump bottom plate, and then place the bottom plate under the pump housing.

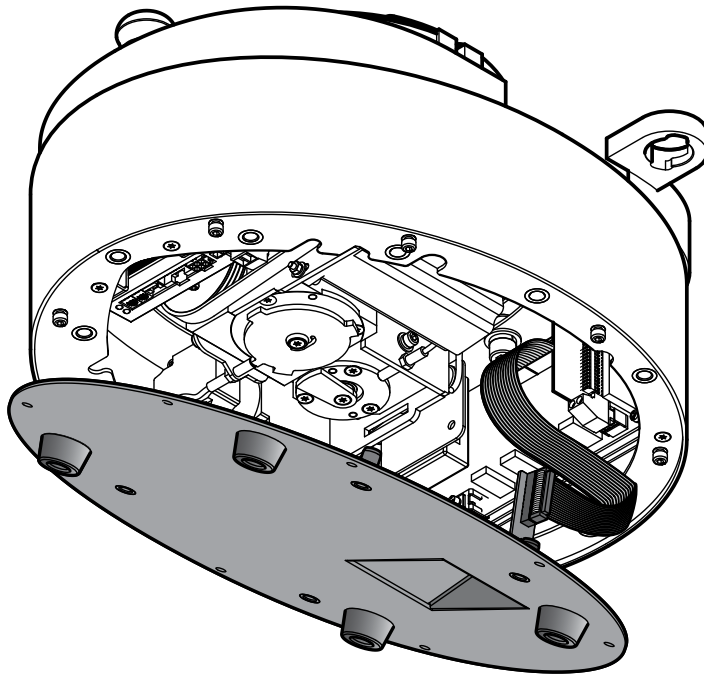

55. Use a T20 star screwdriver to install the 8 screws that attach the bottom plate to the pump housing.

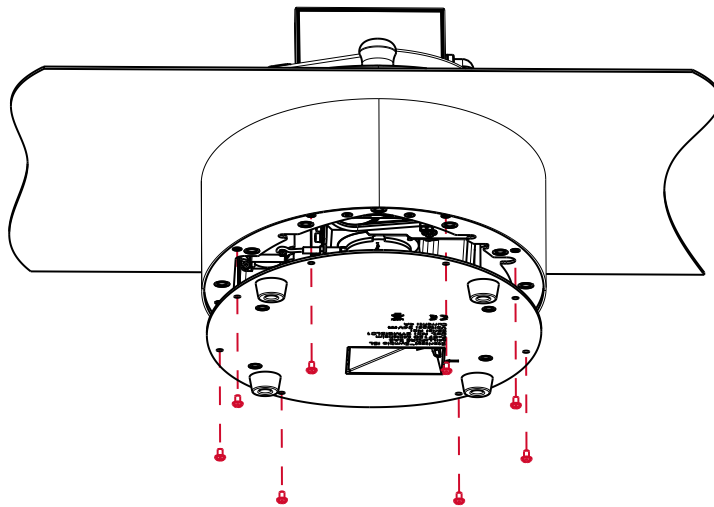

56. Connect the communication hub pump connection cord to the pump power inlet.
57. Then connect the communication hub to power source using the power cord delivered with the pump.



**NOTE**

The communication hub can be installed under the isolator using the optional communication hub holder for isolator (See [Installing the Communication Hub under the Isolator](#)). It can also be fixed to one of the isolator feet, using the optional communication hub holder for hoods (see [Accessories and Replacement Parts](#)).

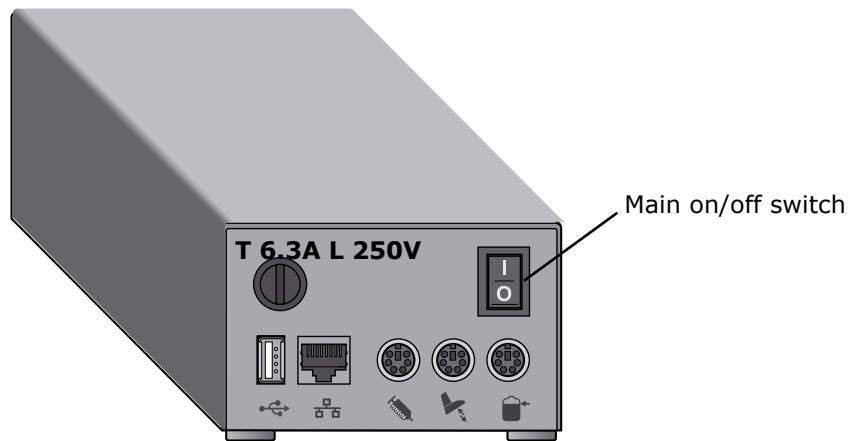

58. Switch on the communication hub by pressing the on/off switch (position I).



59. Simultaneously press and hold the pump on/off  and the open/close  buttons. The screen displays the range of Steritest™ devices. This is followed by the welcome screen:



60. After a few seconds, the following screen displays:

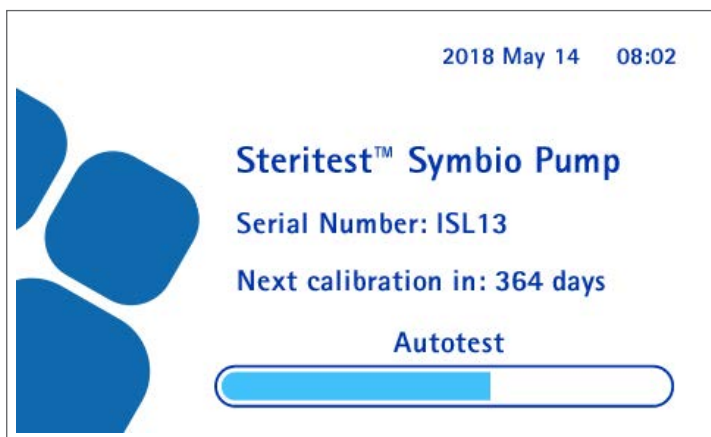

61. When the autotest is complete, the following screen displays. A ✓ symbol in a check box indicates that an accessory or data source is connected to the communication hub.

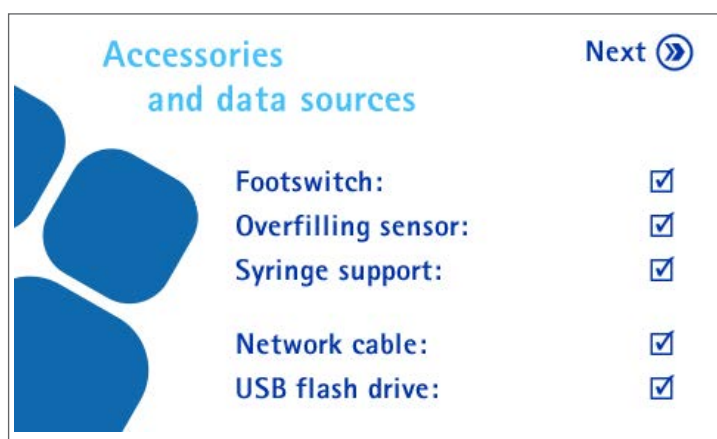

62. Press the  button. The installation menu displays.

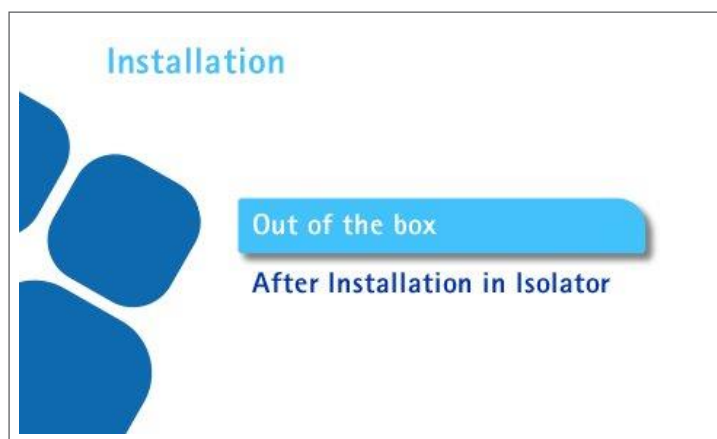

63. Turn and press the control knob to select **After Installation in Isolator**.

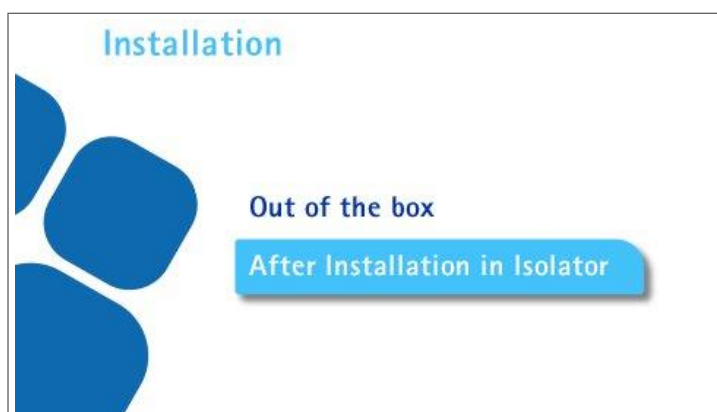

64. Press the control knob. The **After Installation in Isolator** screen displays.

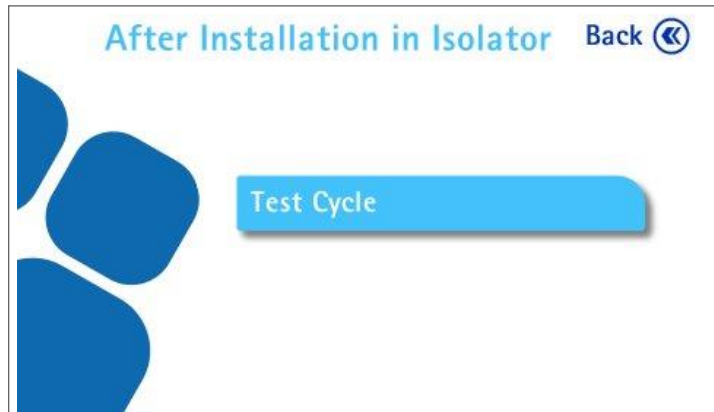

65. Press the control knob to begin the test cycles. Three cycles will be performed.

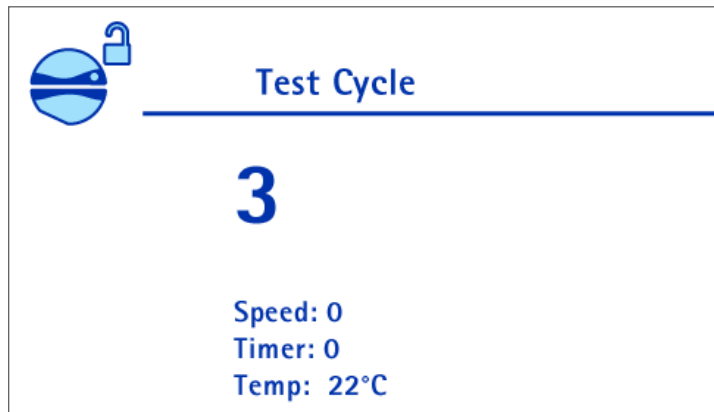

66. After the pump head closes, the pump starts automatically, and the 3 test cycles are performed.

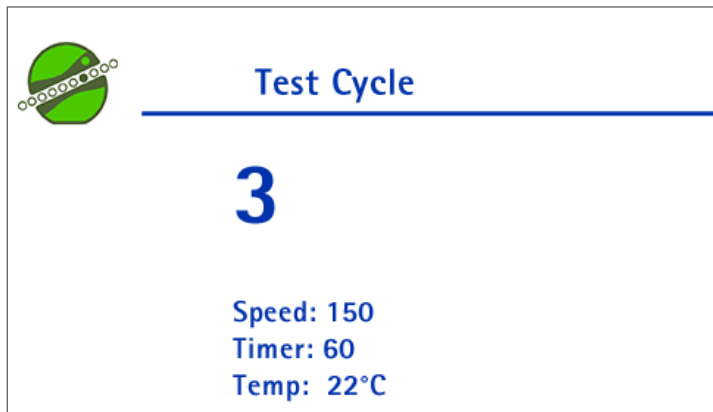



67. When all three test cycles complete with no error, the **Test Cycle OK** screen displays.



68. Switch off the communication hub by pressing the on/off switch (position O). The Shutdown screen displays.



69. Disconnect the communication hub pump connection cord from the pump power inlet.



## Installing the Communication Hub under the Isolator

Use the optional communication hub holder for isolators to install the communication hub under the isolator table (see [Accessories and Replacement Parts](#)). Multiple configurations are possible.

### Installing the Communication Hub on the Side, High Version

#### Installing to the Left of the Pump

1. Use the small screws and washers to attach the holder to the bottom of the communication hub.

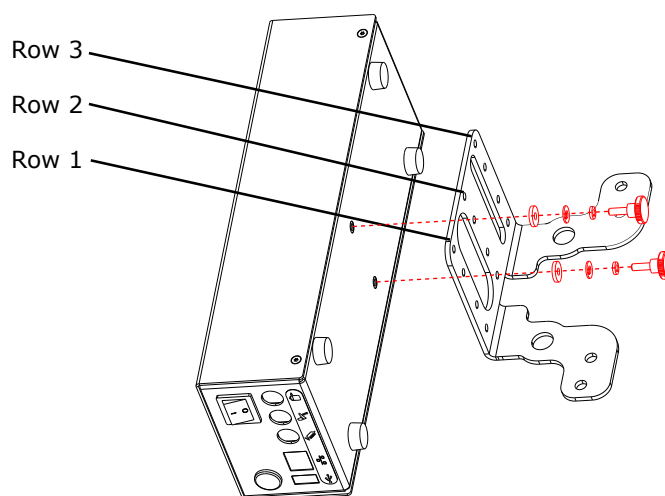

#### NOTE

To install the communication hub in alignment with the pump housing (the default position), use the holes in row 2. To install the hub toward the front of the isolator, use the holes in row 1. To install the hub toward the rear of the isolator, use the holes in row 3.

2. Use the large screws and washers to attach the holder to the bottom of the pump housing.

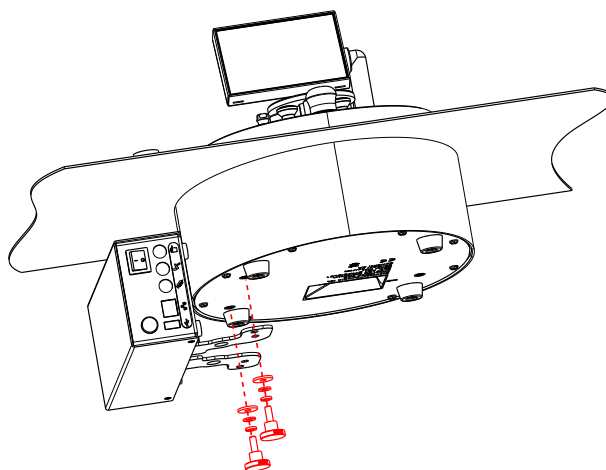

## Installing to the Right of the Pump

1. Use the small screws and washers to attach the holder to the bottom of the communication hub.

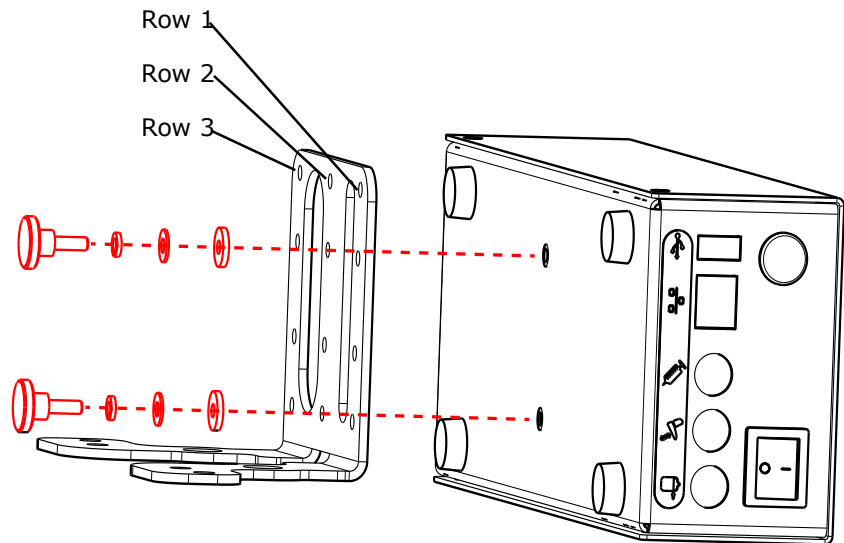

### NOTE

To install the communication hub in alignment with the pump housing (the default position), use the holes in row 2. To install the hub toward the front of the isolator, use the holes in row 1. To install the hub toward the rear of the isolator, use the holes in row 3.

2. Use the large screws and washers to attach the holder to the bottom of the pump housing.

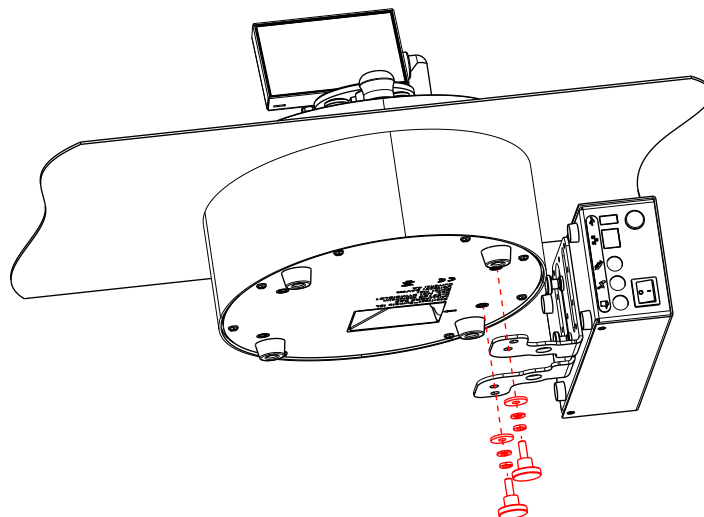

# Installing the Communication Hub on the side, Low Version

## Installing to the Left of the Pump

1. Use the small screws and washers to attach the holder to the bottom of the communication hub.

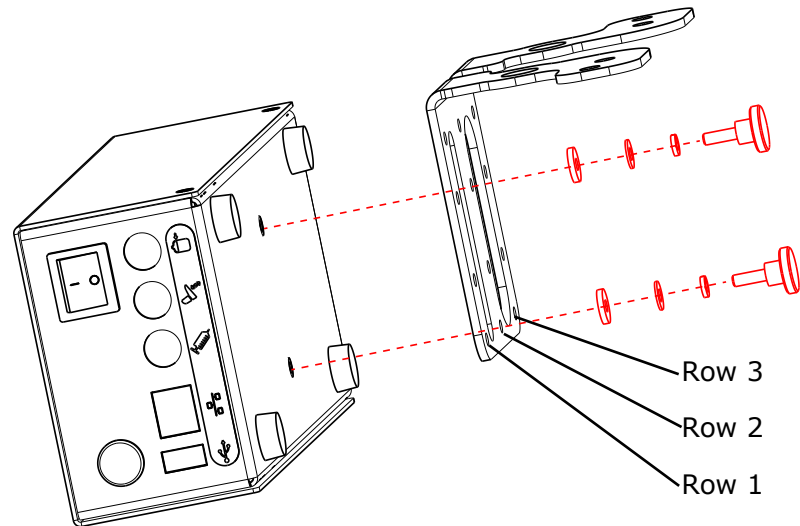

### NOTE

To install the communication hub in alignment with the pump housing (the default position), use the holes in row 2. To install the hub toward the front of the isolator, use the holes in row 1. To install the hub toward the rear of the isolator, use the holes in row 3.

2. Use the large screws and washers to attach the holder to the bottom of the pump housing.

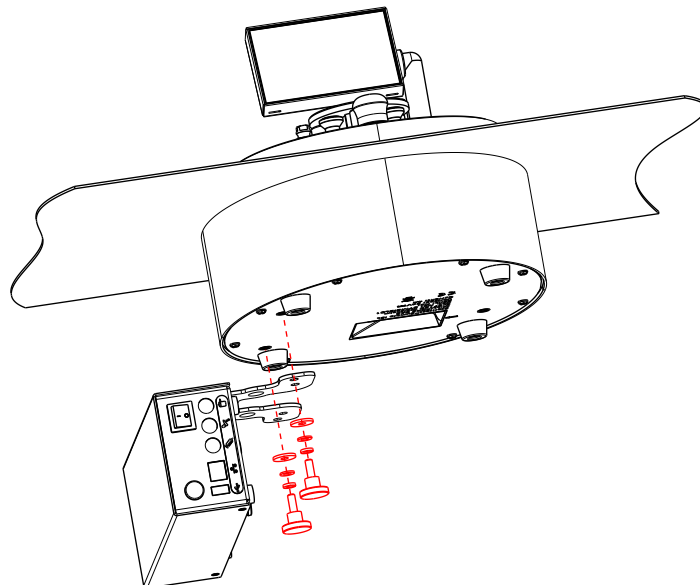

## Installing to the Right of the Pump

1. Use the small screws and washers to attach the holder to the bottom of the communication hub.

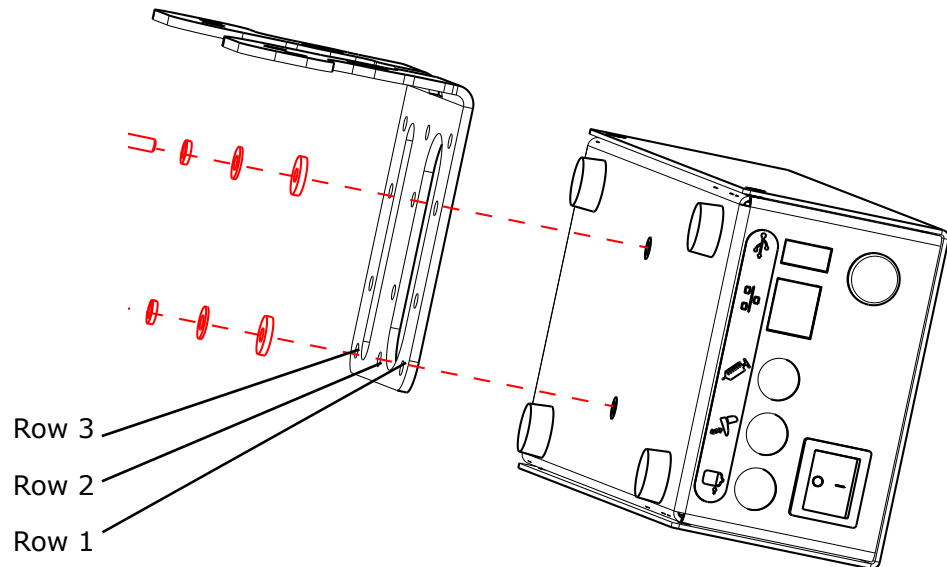

### NOTE

To install the communication hub in alignment with the pump housing (the default position), use the holes in row 2. To install the hub toward the front of the isolator, use the holes in row 1. To install the hub toward the rear of the isolator, use the holes in row 3.

2. Use the large screws and washers to attach the holder to the bottom of the pump housing.

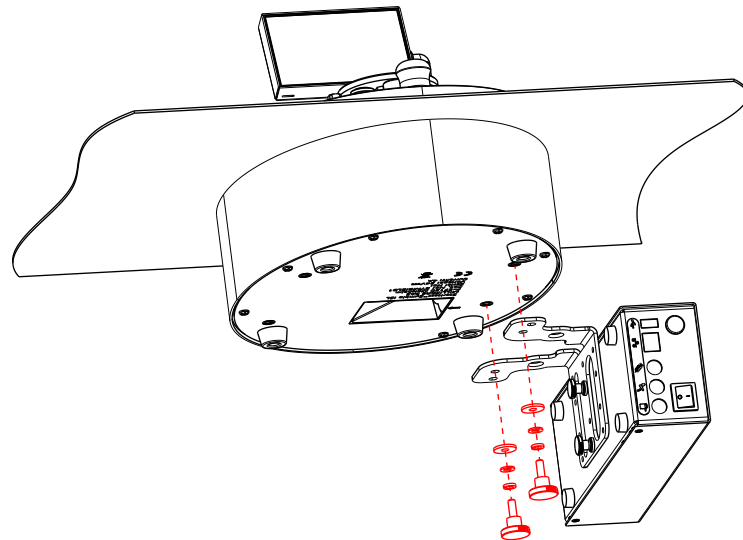

# Installing the Communication Hub below the Pump Housing

1. Use the small screws and washers to attach the holder to the bottom of the communication hub.

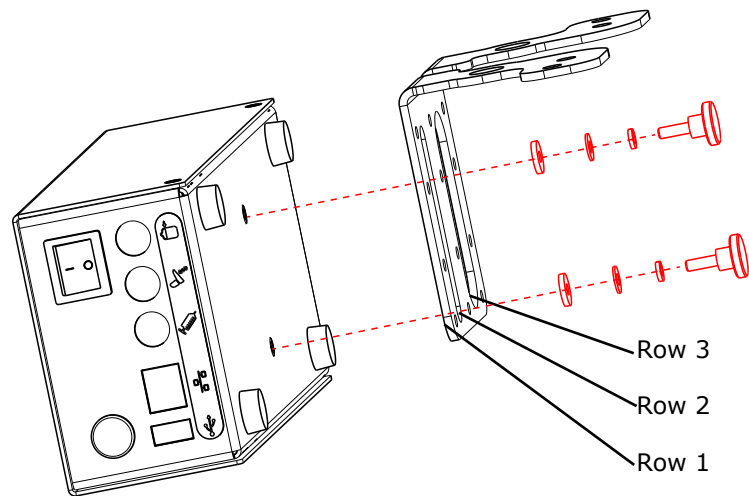

## NOTE

To install the communication hub in alignment with the isolator (the default position), use the holes in row 2. To install the hub toward the front of the isolator, use the holes in row 1. To install the hub toward the rear of the isolator, use the holes in row 3.

2. Connect the end of the communication hub pump connection cord to the pump power inlet.
3. Use the large screws and washers to attach the holder to the bottom of the pump housing.

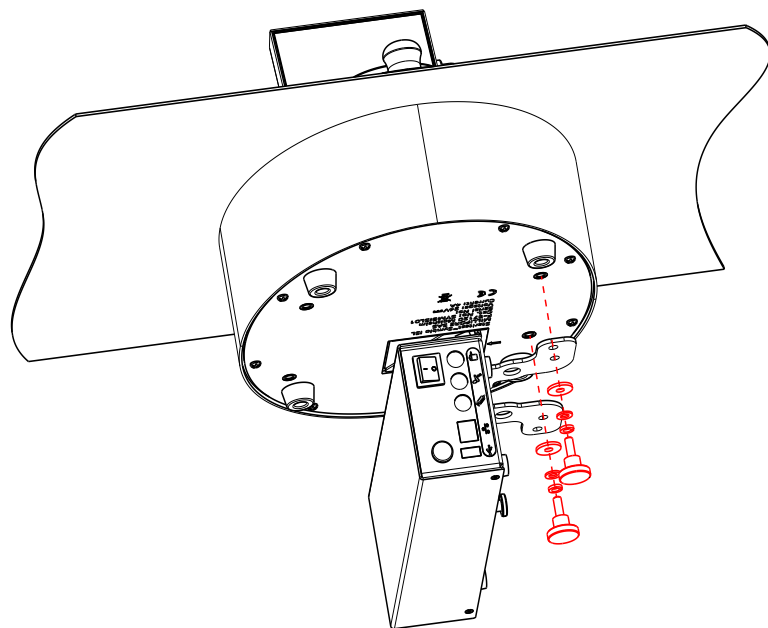

## Accessories and Replacement Parts

Description	Quantity per pack	Catalog Number
<b>Steritest™ Symbio Pump</b>		
Steritest™ Symbio ISL Pump Kit, 2 media	1	SYMBISL01WW*
<b>Steritest™ Symbio Pump Services</b>		
Steritest™ Symbio pumps validation protocol (A4 format)	1	SYMBA4VP1
Steritest™ Symbio pumps validation protocol US (letter format)	1	SYMBLTVP1
NOTE: Contact our sales representative or Technical Service for more information about our application support, validation services, maintenance, and repair services.		
<b>Steritest™ Symbio Pump Accessories</b>		
Steritest™ Pump footswitch	1	SYMBFSW01
Steritest™ glass ampoule breaker	1	SYMBABR01
Steritest™ pumps syringe support	1	SYMBSYS01
Steritest™ Symbio waste overflow sensor for solid containers	1	SYMBWFS01
Pressure control kit for Steritest™ pumps	1	TQ00PSI01
Steritest™ holder for sterile bags and Steridilutor vent chamber	1	SYMBSVB01
Steritest™ Symbio communication hub holder for isolators	1	SYMBCHI01
Steritest™ Symbio pumps universal shipment case	1	SYMBSCA01
Steritest™ carrying trays for 5 canisters	8	SYMBCAN08
Steritest™ rack to hold up to 4 canister carrying trays	2	SYMBRACK2
<b>Replacement parts</b>		
Steritest™ Symbio bottle holder (basket and support rod)	1	SYMBBTH01
Steritest™ Symbio bottle holder basket (with fastening screw)	1	SYMBCBH01
Steritest™ Symbio accessories support rod	1	SYMBASR01
Steritest™ Symbio accessories fastening screw	1	SYMBAFS01
Steritest™ Symbio accessories fastening screw clip	1	SYMBFSC01
Steritest™ Symbio 2 media drain tray container	1	SYMBDTC01
Steritest™ Symbio drain tray support for 2 canisters, ISL pump	1	SYMBDSL01
Steritest™ Symbio drain tray support O-rings	5	SYMBDSR02
Steritest™ Symbio drain tray support express coupling	1	SYMBSEC01
Steritest™ Symbio complete drain tray for 2 canisters, ISL pump	1	SYMBDTL01
Drain tubing for Steritest™ pumps, silicone, 1.5 meters	1	SYMBTBG01
Steritest™ Symbio control knob	1	SYMBKNB01
Steritest™ Symbio communication hub	1	SYMBCHB01
Steritest™ Symbio communication hub fuses kit, 6.3A	2	SYMBHFK6A
Steritest™ Symbio communication hub fuses kit, 3.15A	2	SYMBHFK3A
Pump head cover for Steritest™ Symbio 2 media	1	SYMBHEC01
Power cord for North America, Central America, Mexico	1	FTPF02471
Power cord for Europe	1	FTPF01866
Power cord for United Kingdom, Ireland, Malaysia, Singapore, Hong Kong	1	SIMCABLE1
Power cord for Denmark	1	SIMCABLE2
Power cord for South Africa	1	SIMCABLE3
Power cord for Switzerland	1	SIMCABLE4
Power cord for China	1	SIMCABLE5
Power cord for India	1	SIMCABLE6
Power cord for Japan	1	SIMCABLE7
Power cord for Australia, New Zealand, Argentina	1	SIMCABLE8



Description	Quantity per pack	Catalog Number
Power cord for Italy	1	SIMCABLE9
Power cord for Brazil	1	SIMCABLE11
Steritest™ Symbio flat seal for ISL pump	1	SYMBFSI01
<b>Software</b> (Available at <a href="http://www.millipore.com/steritest-software">www.millipore.com/steritest-software</a> )		
Steritest™ Symbio Software	—	—
<b>Consumables</b>		
Steritest™ devices, culture media and rinsing fluids	—	Visit our website or contact our sales representative.
<b>Documentation</b> (Available at <a href="http://www.millipore.com/steritest-symbio">www.millipore.com/steritest-symbio</a> )		
Steritest™ Symbio Pumps User Guide	1	PF16598
Steritest™ Symbio ISL Pump Installation Guide	1	PF16599
Steritest™ Symbio Software User Guide	1	PF16600
Steritest™ Symbio Pump Startup Quick Guide	1	PF16601
Steritest™ Symbio Pump User Interface Quick Guide	1	PF16602
Steritest™ Symbio Software Quick Guide	1	PF16603
Steritest™ Symbio Pumps Isolator Installation Checklist	1	PF17360

\* Country code to be defined at ordering step



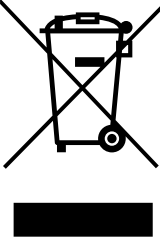

## Symbols Referenced

	<p>The presence of this logo on the product testifies the compliance of the Steritest™™ Symbio Pump with the following European Union directives:</p> <ul style="list-style-type: none"><li>• Electromagnetic compatibility 2014/30/EU</li><li>• Low voltage directive 2014/35/EU</li><li>• Restriction of the use of certain Hazardous Substances in electrical equipment (RoHS) 2011/65/EU</li></ul>
	<ul style="list-style-type: none"><li>• In accordance to the European Union Directive 2012/19/EC on Waste Electric and Electronic Equipment (WEEE), the presence of this logo on the product indicates that it should not be disposed of in the normal waste stream but collected separately.</li></ul> <p>Go to <a href="http://www.millipore.com/weee">www.millipore.com/weee</a> for details on how to ensure proper treatment of the product in different countries.</p>



## Standard Product Warranty

The applicable warranty for the products listed in this publication may be found at: [www.millipore.com/ec/cp3/terms](http://www.millipore.com/ec/cp3/terms) (within the “Terms and Conditions of Sale” applicable to your purchase transactions.)

### **WARNING:**

The pump must be opened to proceed to the installation. This operation does not void the warranty. However, to preserve this warranty, it is mandatory to execute the short test cycles (before and after installation) described in this installation guide.

Use the Steritest™ Symbio Pumps Isolator Installation Checklist (PF17360) to document the proper execution of the installation steps and test cycles.

(Download the checklist at [www.millipore.com/steritest-symbio](http://www.millipore.com/steritest-symbio))

Deliver this document to the end user of the pump.



# Technical Assistance

For more information visit [www.millipore.com/techservice](http://www.millipore.com/techservice)



Steridilutor, Sterisolutest, the vibrant M, Millipore, and Sigma-Aldrich are trademarks of Merck KGaA, Darmstadt, Germany or its affiliates. Detailed information on trademarks is available via publicly accessible resources.

© 2018 Merck KGaA, Darmstadt, Germany and/or its affiliates. All Rights Reserved.

