

08168 Timestrip® PLUS 8°C

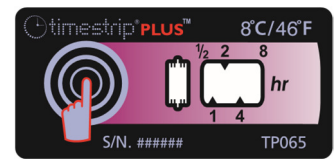

General

Each Timestrip® PLUS indicator is a small, self-adhesive label that can be attached to or integrated into a product, package or carrying card (see adhesive specification in Appendix 1 below for further details). It monitors temperature and indicates when a maximum threshold has been breached. It is irreversible and also records the total time duration of one or more breaches. Each product in the range has been engineered for a different maximum threshold temperature, so customers can choose the Timestrip® PLUS indicator that best suits their needs.

How to use

Timestrip® PLUS indicators are completely inert prior to activation and can be stored at room temperature.

To activate Timestrip® PLUS, the surrounding temperature must be above the stated threshold temperature so that the blue dye liquid can be released from the button. Fully squeeze the button and check that the first window turns blue and the word "ON" appears. If not, immediately re-squeeze the button fully. Within 2-3 minutes of activation, place the indicator below its STOP temperature for a minimum of one hour so that the liquid freezes and the indicator is fully conditioned and ready to use. If the carrying card or the product to be monitored is already at or below the STOP temperature, then the indicator can be stuck directly to it by removing the adhesive liner on the back.

Threshold Temperature	STOP Temperature*	Run-Out Window**	Time Marks in Hours
+8°C/+46°F	+6°C/+43°F	8 hours	0.5, 1, 2, 4, 8

* The temperature at which the run-time advancement (the movement of the blue dye) will stop.

** The run-out window is calibrated to an isothermal temperature of +2°C above the stated threshold temperature.

I) Performance Specifications

Temperature Accuracy:	± 1°C/2°F
Time Accuracy:	± 15 % in time under isothermal conditions
Progress Isotherms:	See Fig. 1
Display:	Continuous, irreversible
Usage:	The usage of the product in any assembly or production line must be agreed upon in advance, as it may alter performance specifications.

II) Product Specification

Button Position:	Button on Top Layer (BOT)
Color of Progressing Front:	Blue
Adhesive:	2641, Pressure sensitive, -40°C to +110°C, Finger-lift – see Appendix 1
Product drawing:	See Fig. 2
Graphics:	See Fig. 3
Other:	Not suitable for immersion in water
Remark:	Run-time window length will vary slightly between production batches.



III) Product Construction

The indicator is constructed of a polymeric assembly multilayer and aluminum-plastic laminate. It encapsulates colored liquid chemicals. Maximum weight of colorant is <0.5 mg. Liquid chemicals are listed in the Food Chemicals Codex and/or approved by the Food and Drug Administration (FDA) under Title 21, and/or considered generally recognized as safe (GRAS). All materials are non-toxic, latex and PVC-free.

IV) Storage Conditions (un-activated)

- Store in cool dark environment
- Recommended: 22°C/72°F at 20-80% RH
- Please note that before activation, the product can tolerate short term exposure during transit (hours or a few days) to temperatures in the range -30°C to +55°C. However, long term storage should be under recommended conditions.

VI) Shelf-life

- 2 years from date of shipping

Figure 1: Progress Isotherm

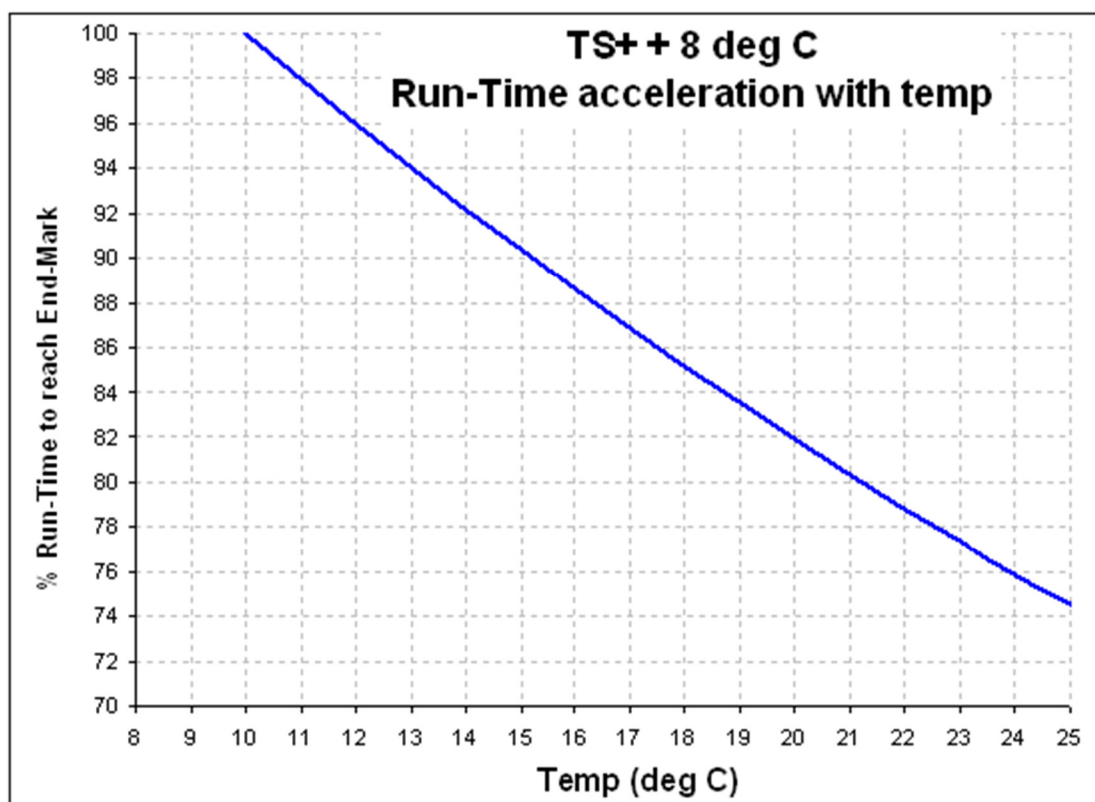

The vibrant M, Supelco, and Sigma-Aldrich are trademarks of Merck KGaA, Darmstadt, Germany or its affiliates. Detailed information on trademarks is available via publicly accessible resources.
© 2018 Merck KGaA, Darmstadt, Germany and/or its affiliates. All Rights Reserved.

The life science business of Merck KGaA, Darmstadt, Germany operates as MilliporeSigma in the US and Canada.



Figure 2: Product Drawing

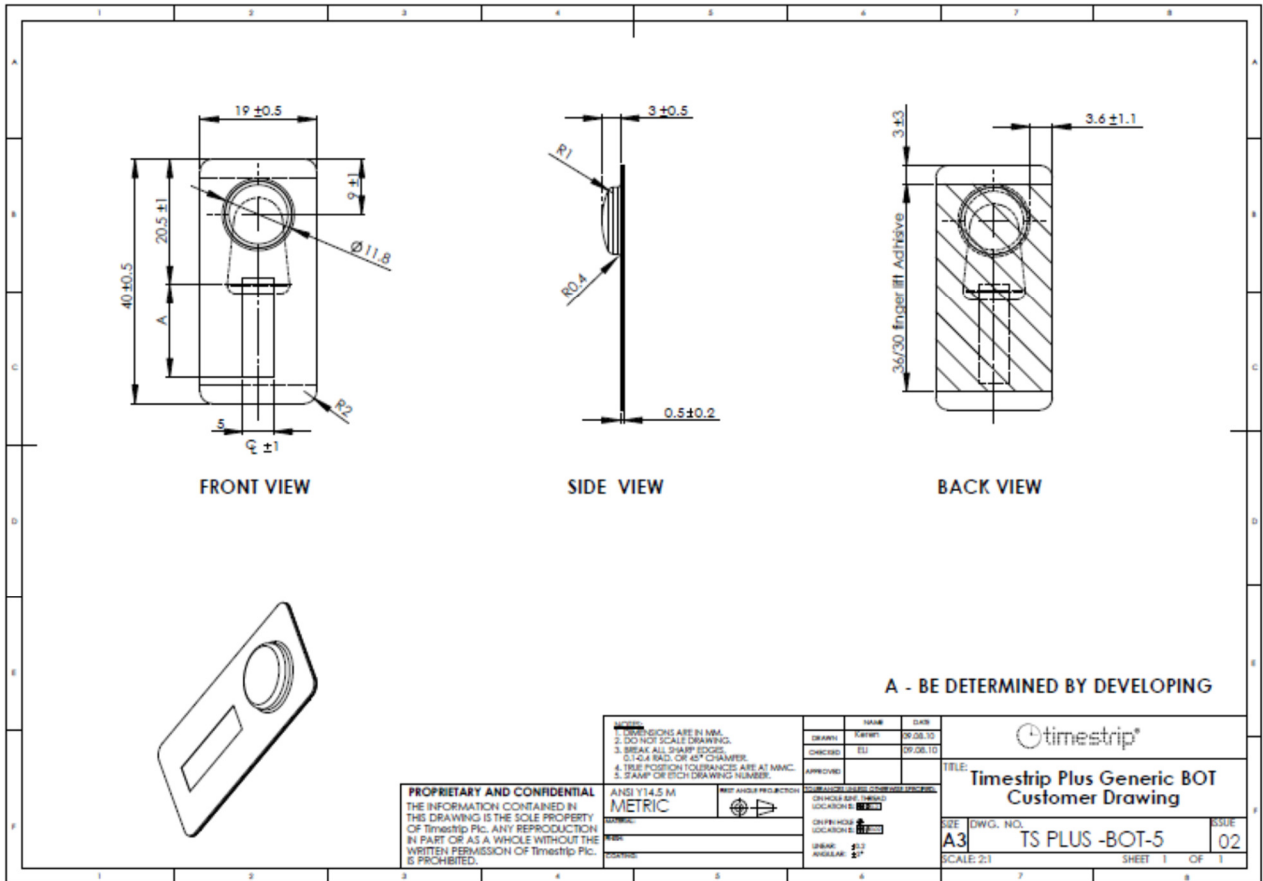

The vibrant M, Supelco, and Sigma-Aldrich are trademarks of Merck KGaA, Darmstadt, Germany or its affiliates. Detailed information on trademarks is available via publicly accessible resources.
 © 2018 Merck KGaA, Darmstadt, Germany and/or its affiliates. All Rights Reserved.

The life science business of Merck KGaA, Darmstadt, Germany operates as MilliporeSigma in the US and Canada.



Figure 3: Graphics

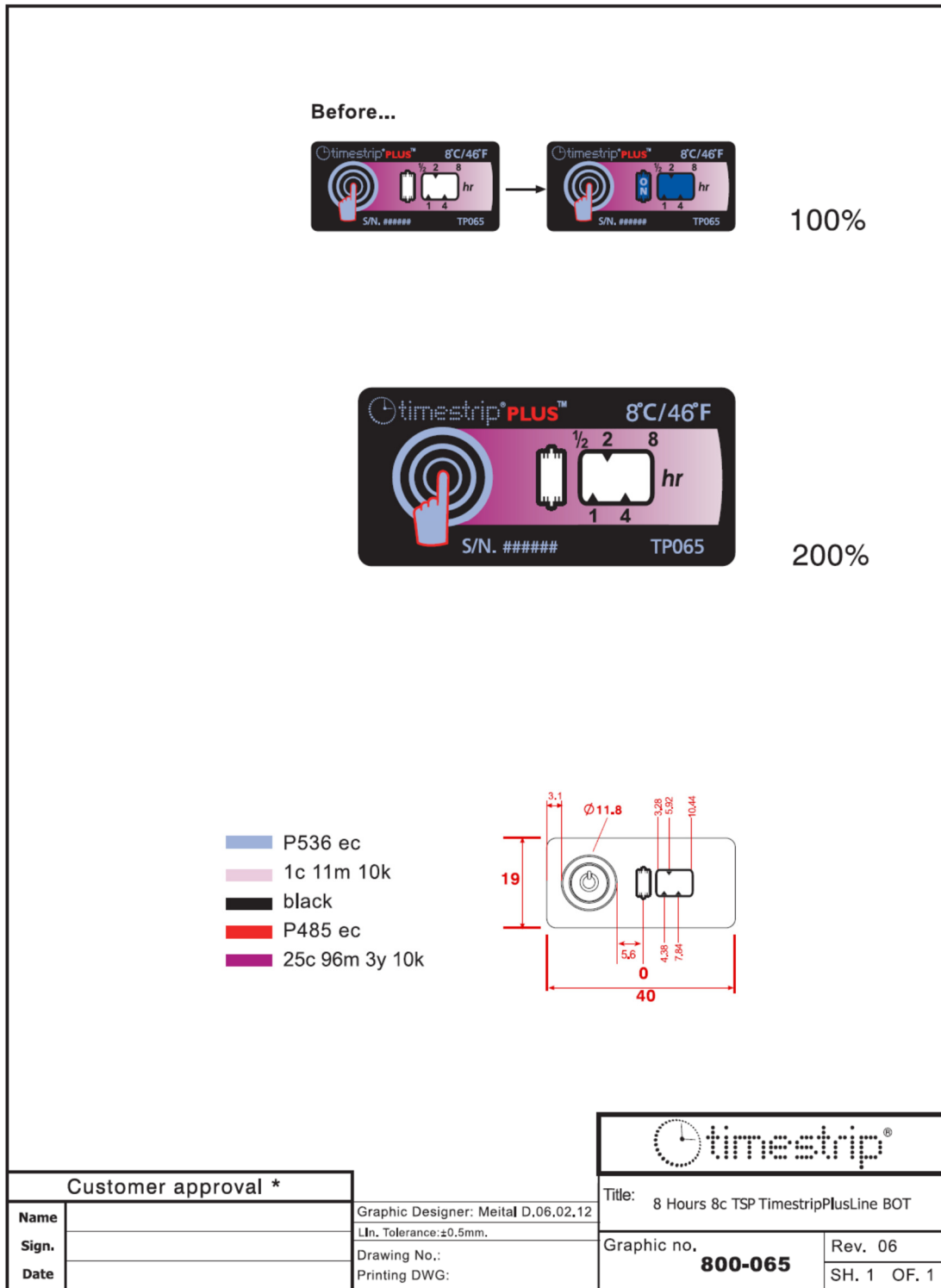

The vibrant M, Supelco, and Sigma-Aldrich are trademarks of Merck KGaA, Darmstadt, Germany or its affiliates. Detailed information on trademarks is available via publicly accessible resources.
© 2018 Merck KGaA, Darmstadt, Germany and/or its affiliates. All Rights Reserved.



Appendix 1

Pressure Sensitive Adhesive Data

Timestrip Adhesive - Product # 2641

	<u>SUBSTANCE</u>		<u>THICKNESS</u>
Adhesive	40gsm		
Tissue	12gsm	Adhesive & Carrier	95 micron
Adhesive	45gsm		
Liner	80gsm	Liner	70 micron

PRODUCT DESCRIPTION

A permanent tape with a tissue carrier. The adhesive is a modified acrylic, offering good UV light and chemical resistance together with high performance especially to difficult surfaces. The liner is a two side release system.

APPLICATIONS

The high tack/adhesion of 2641 makes it especially useful for applications involving the bonding of difficult substrates such as many foams, rubbers and polythene type materials. The product is also useful for various mounting applications.

ADHESIVE PROPERTIES

		<u>20 min</u>	<u>24 hour</u>	<u>TEST METHOD</u>
Adhesion to steel	open side	1300 N/M	1400 N/M	BS7116:1990 - D
	closed side	1300 N/M	1400 N/M	BS7116:1990 - D
Shear Adhesion	open side	5 hours		BS7116:1990 - B
	closed side	5 hours		BS7116:1990 - B
Release of liner from adhesive		10 N/M		BS7116:1990 - E

THERMAL PROPERTIES

Recommended service temperature range	-40°C to 110°C	-40°F to 230°F
Application temperature range	5°C to 60°C	41°F to 140°F

SHELF LIFE

Minimum shelf life when stored in closed cartons away from direct sources of heat and sunlight.

2 Years

HEALTH AND SAFETY INFORMATION

The adhesive conforms to F&DA Regulation 175.105.

Note

Values given are average and should not be taken as a maximum or minimum for specification purposes. Specific technical details, applications information and suggested uses available.

