

# Spectroquant® Thermoreactor TR 320

Operating manual

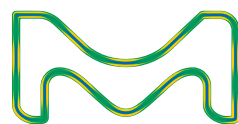

**Accuracy when going to press**

The use of advanced technology and the high quality standard of our instruments are the result of continuous development. This may result in differences between this operating manual and your instrument. Also, we cannot guarantee that there are absolutely no errors in this manual. Therefore, we are sure you will understand that we cannot accept any legal claims resulting from the data, figures or descriptions.

**Warranty**

We guarantee the instrument described for 2 years from the date of purchase. The instrument warranty covers manufacturing faults that are discovered within the warranty period. The warranty excludes components that are replaced as part of maintenance, e.g. batteries.

The warranty claim extends to restoring the instrument to readiness for use but not, however, to any further claim for damages. Improper handling or unauthorized opening of the instrument invalidates any warranty claim.

To ascertain the warranty liability, return the instrument and proof of purchase together with the date of purchase freight paid or pre-paid.

**Copyright**

© Merck KGaA  
64271 Darmstadt  
Germany  
[www.sigmaaldrich.com/photometry](http://www.sigmaaldrich.com/photometry)

EMD Millipore Corporation, 400 Summit Drive,  
Burlington MA 01803, USA

Sigma-Aldrich Canada Co. or Millipore  
(Canada) Ltd. , 2149 Winston Park,  
Dr. Oakville, Ontario, L6H 6J8

Reprinting - even as excerpts - is only allowed with the explicit written authorization of Merck KGaA, Darmstadt, Germany.

# Contents

- 1 Overview ..... 5**
  - 1.1 Components of the thermoreactor.....6
- 2 Safety ..... 7**
  - 2.1 Safety information .....7
    - 2.1.1 Safety information in this operating manual .....7
    - 2.1.2 Safety signs on the product.....7
    - 2.1.3 Further documents providing safety information .....7
  - 2.2 Safe operation.....8
    - 2.2.1 Authorized use .....8
    - 2.2.2 Requirements for safe operation .....8
    - 2.2.3 Unauthorized use .....9
  - 2.3 Personal protective equipment.....9
- 3 Commissioning ..... 10**
  - 3.1 General handling instructions ..... 10
  - 3.2 Scope of delivery ..... 10
  - 3.3 Unpacking and positioning ..... 10
  - 3.4 Initial commissioning..... 11
- 4 Basic principles of operation..... 14**
  - 4.1 Operating and display elements..... 14
    - 4.1.1 Keys..... 15
    - 4.1.2 Display ..... 16
    - 4.1.3 Control lamps (LEDs) ..... 16
  - 4.2 Operating modes ..... 17

---

<b>5</b>	<b>Operation.....</b>	<b>18</b>
5.1	Inserting and removing the reaction cells ....	18
5.2	Starting a temperature program .....	18
5.3	Stopping a temperature program .....	21
5.4	Settings.....	22
5.4.1	Setting the display contrast.....	22
5.4.2	Setting the timer for the reaction time .....	23
<b>6</b>	<b>Maintenance, cleaning, disposal ...</b>	<b>24</b>
6.1	Maintenance.....	24
6.2	Exchanging the fuses .....	24
6.3	Cleaning the enclosure .....	25
6.4	Cleaning the thermoblocks of spilled cell contents .....	25
6.5	Disposal .....	26
<b>7</b>	<b>What to do if... ..</b>	<b>27</b>
<b>8</b>	<b>Technical Data .....</b>	<b>28</b>
<b>9</b>	<b>Replacement parts and accessories / options.....</b>	<b>30</b>
<b>10</b>	<b>Index .....</b>	<b>31</b>

## 1 Overview

The TR 320 thermoreactor is a dry temperature control device for use in the laboratory. It facilitates and safeguards the digestion with reaction cells.

8 temperature programs are permanently set.

- 1: 148 °C for 120 minutes
- 2: 120 °C for 30 minutes
- 3: 120 °C for 60 minutes
- 4: 120 °C for 120 minutes
- 5: 100 °C for 60 minutes
- 6: 148 °C for 20 minutes
- 7: 150 °C for 120 minutes
- 8: 100 °C for 30 minutes

The thermoreactor accommodates 12 reaction cells with an outer diameter of 16 mm.

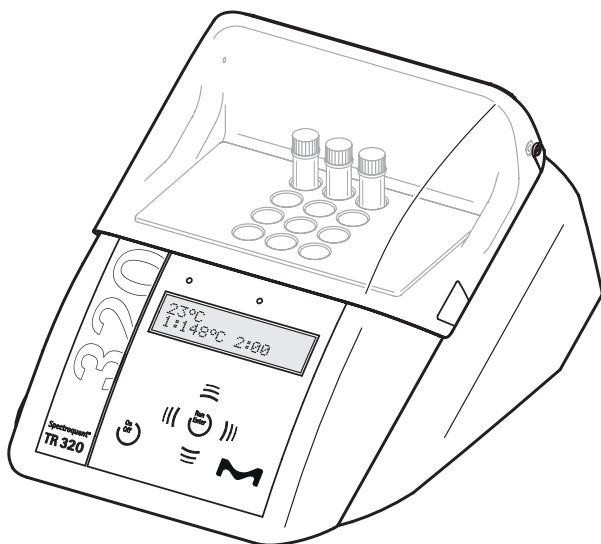

## 1.1 Components of the thermoreactor

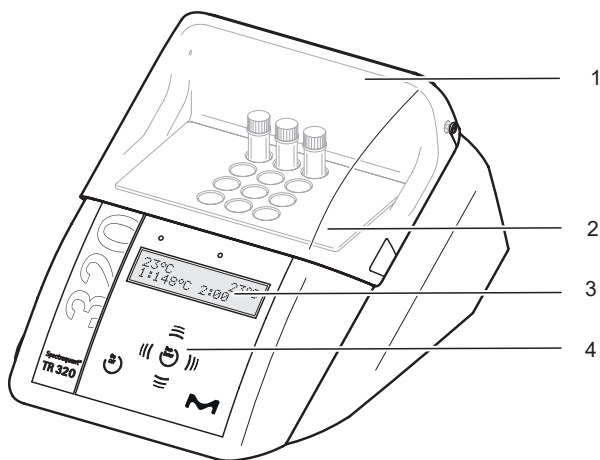

<b>1</b>	Protective cover
<b>2</b>	Thermoblock with cell shafts
<b>3</b>	Display
<b>4</b>	Keypad

## 2 Safety

### 2.1 Safety information

#### 2.1.1 Safety information in this operating manual

This operating manual provides important information on the safe operation of the instrument. Read this operating manual thoroughly and make yourself familiar with the instrument before putting it into operation or working with it. The operating manual must be kept in the vicinity of the instrument so you can always find the information you need.

Important safety instructions are highlighted in this operating manual. They are indicated by the warning symbol (triangle) in the left column. The signal word (e.g. "CAUTION") indicates the level of danger:



#### **WARNING**

**indicates a possibly dangerous situation that can lead to serious (irreversible) injury or death if the safety instruction is not followed.**



#### **CAUTION**

**indicates a possibly dangerous situation that can lead to slight (reversible) injury if the safety instruction is not followed.**

#### **Note**

*indicates a situation where goods might be damaged if the actions mentioned are not taken.*

#### 2.1.2 Safety signs on the product

Note all labels, information signs and safety symbols on the product. A warning symbol (triangle) without text refers to safety information in this operating manual.

#### 2.1.3 Further documents providing safety information

The following documents provide additional information, which you should observe for your safety when working with the thermoreactor:

- Analysis specifications for the cell tests
- Safety datasheets for the cell tests

## 2.2 Safe operation

### 2.2.1 Authorized use

The authorized use is exclusively the carrying out of reactions for photometric determinations, with the aid of commercial test sets, in round cells with a diameter of  $16 \pm 0.2$  mm. Only the operation and running of the product according to the instructions given in this operating manual is authorized (see section 8 TECHNICAL DATA). Any other use is considered unauthorized.

### 2.2.2 Requirements for safe operation

Note the following points for safe operation:

- The product may only be operated according to the authorized use specified above.
- The product may only be supplied with power by the energy sources mentioned in this operating manual.
- The product may only be operated under the environmental conditions mentioned in this operating manual.
- The round cells to be used including the screw caps must be suitable and tested for the intended application (temperature resistance, chemical stability against the reaction mixture, pressure resistance, tightness).
- The reaction mixture in the round cells must not be inflammable.
- For operation, the cell shafts have to be clean and free of obstacles.
- Round cells may only be inserted and heated with the cap screwed on.
- The instrument may only be opened if this is explicitly described in this operating manual (example: inserting and removing the cells).
- The connection cable and fuses may only be replaced with original replacement parts.



**2.2.3 Unauthorized use**

The product must not be put into operation if:

- it is visibly damaged (e.g. after being transported)
- it was stored under adverse conditions for a lengthy period of time (storing conditions, see section 8 TECHNICAL DATA).

**2.3 Personal protective equipment**

For your safety, wear the following personal protective equipment to be protected against any (residual) risk while carrying out certain activities:

- protective goggles and protective clothing with long sleeves as a protection against any splashes of hot and corrosive liquids
- chemical-resistant gloves as a protection against contact with possibly noxious substances
- heat protection gloves to touch hot parts
- safety shoes for protection against heavy falling objects

Activity	Protective goggles	Protective clothing with long sleeves	Chemical resistant gloves	Heat protection gloves	Safety shoes
Transport, positioning					✓
Inserting or removing cells	✓	✓		✓ (if the instrument is hot)	
Cleaning after a cell has broken or its content has been spilled	✓	✓	✓		

### 3 Commissioning

#### 3.1 General handling instructions

Always protect the instrument against conditions that might damage its mechanical and electronic components.

Observe the following points especially:

- For operation and storage, the temperature and air humidity must be within the limits specified in section 8 TECHNICAL DATA.
- The following impacts on the instrument have to be avoided in any situation:
  - Extreme dust, moisture and wetness
  - Intensive light and heat
  - Corrosive or solvent-containing vapors.
- Any spilled or spattered liquid and broken glass in the thermoblock have to be removed immediately (see section 6.4).
- The protection cover should always be closed when the instrument is not operating.
- The thermoblock must be empty while the instrument is being transported.

#### 3.2 Scope of delivery

- Thermoreactor TR 320
- Power cable
- Operating manual

#### 3.3 Unpacking and positioning



##### CAUTION

**The instrument is quite heavy. Therefore, there is a risk of injury for the lower extremities if it falls down. Wear safety shoes during the unpacking and positioning of the instrument.**



##### CAUTION

**Fire hazard! The thermoreactor may only be operated on a surface of nonflammable material. The ventilation slots in the bottom and rear panel of the instrument must always be free. Air circulation in the area of the ventilation slots must not be impeded.**

**Note**

Please make sure to keep the original packing including the inner packages so the instrument will be optimally protected against strong impacts if it has to be transported. The original packing is also required for the appropriate return transport if the instrument has to be repaired. Please note that the warranty does not cover any damage caused by inappropriate transport.

**Note**

If the thermoreactor was transported from a cold environment to a warm environment, the formation of condensate can lead to the faulty functioning of the instrument. Wait until the thermoreactor has adapted to the changed environmental conditions before putting it back into operation.

**Setting up the thermoreactor**

- |   |  |
|---|--|
| 1 | Place the thermoreactor firmly on a flat, non-flammable surface.   |
| 2 | Make sure that there is enough space between the thermoreactor and other instruments or devices that are heat sensitive. |

**Adjusting the line voltage**

**3.4 Initial commissioning**

- |   |   |
|---|---|
| 3 | Check whether the arrow on the back of the housing points to the line voltage stated on the fuse holder that is provided by the power supply system (115 or 230 V). |
|---|---|

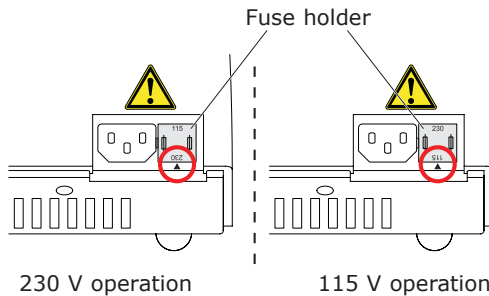

- |   |   |
|---|---|
| 4 | If the wrong line voltage is set, perform steps 5 to 7. |
| 5 | Pull out the fuse holder.                               |

- |   |  |
|---|--|
| 6 | Turn the fuse holder so that the arrow on the housing points to the line voltage (115 or 230 V) provided by the power supply system. |
| 7 | Push the fusion holder completely in.  |

**Connecting the power cable**

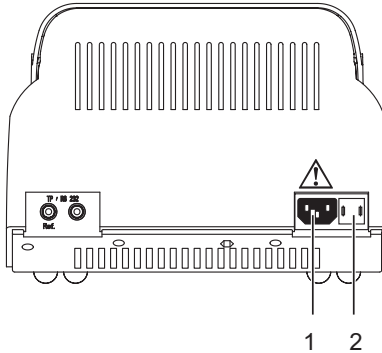

- |   |                            |
|---|----------------------------|
| 1 | Connection for power cable |
| 2 | Fuse holder                |



**CAUTION**

Each time before commissioning, check the outside of the power cable for intactness. A damaged cable must be removed and replaced by an original power cable. Original power cables are listed in section 9 REPLACEMENT PARTS AND ACCESSORIES / OPTIONS. Exclusively use original power cables suitable for the country-specific power supply system. Do not use any line adapt-ers (fire hazard).



If the power cable is not suitable for the power supply system of your country, please contact your supplier for an exchange.

- |   |  |
|---|--|
| 8 | Connect the power cable to the socket 1 on the thermoreactor.  |
| 9 | Connect the power cable to an easily available power socket.<br>The thermoreactor is now in the Standby mode.<br>The display shows the name of the instrument. |

TR 320      U X.XX
--------------------

The thermoreactor is ready for operation.

## 4 Basic principles of operation

This section provides you with basic information on how to operate the thermoreactor.

### 4.1 Operating and display elements

Using the six keys of the keypad (see section 4.1.1) you control the thermoreactor.





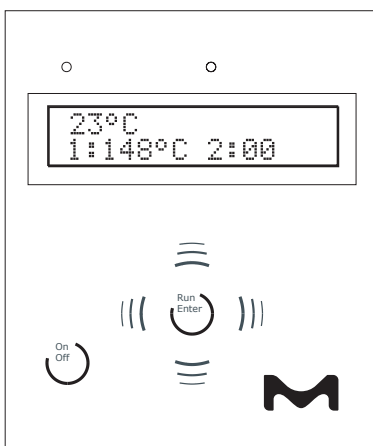

Temperature values, available temperature programs or settings can be viewed in the display (see section 4.1.2).

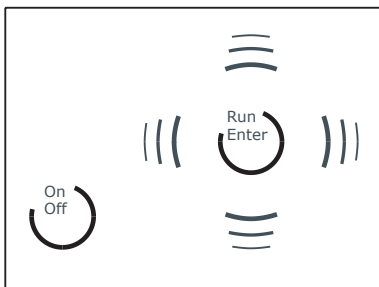
The color (red or green) of the control lamps above the operating panel and their state (flashing or illuminated) show the current operating state of the thermoreactor (see section 4.1.3).



## 4.1.1 Keys



Key	Meaning
	On/off switch
	<ul style="list-style-type: none"> <li>Making or confirming a selection</li> <li>or</li> <li>Starting the timer for the reaction time (active temperature program)</li> </ul>
	Keep  depressed and simultaneously press  : Changing to the <i>SETUP</i> menu from the Standby mode
	<ul style="list-style-type: none"> <li>Changing between the temperature setting and the reaction time setting (in the <i>SETUP</i> menu)</li> <li>or</li> <li>Canceling the active temperature program</li> </ul>
	<ul style="list-style-type: none"> <li>Selecting the temperature program (program selection)</li> <li>or</li> <li>Changing settings and switching between settings (<i>SETUP</i>)</li> <li>Starting the scrolling through settings by keeping the key depressed</li> </ul>

### 4.1.2 Display

Example: Program selection

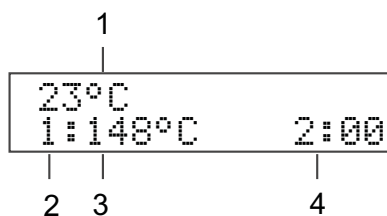

<b>1</b>	Temperature in the thermoblock
<b>2</b>	Number of the temperature program
<b>3</b>	Specified temperature
<b>4</b>	Reaction time in hours and minutes

### 4.1.3 Control lamps (LEDs)

The control lamps above the operating panel are assigned to the thermoblock and indicate the current operating state

<b>LED</b>	<b>flashes</b>	<b>is illuminated</b>
<b>green</b>		Program selection
<b>red</b>	active temperature program: heating period or cooling period	active temperature program: reaction temperature reached
<b>red and green</b>	active temperature program: program canceling selected	

If the control lamps are off the thermoreactor is in the Standby mode.



## 4.2 Operating modes

The thermoreactor has three operating modes:

- Standby

The display shows the model and version number of the thermoreactor.

With the key combination  and  you move to the *SETUP* menu. There you can:

- Setting the display contrast (*CONTRAST:0* to *9*, see section 5.4.1)
- Activating a manual confirmation before the timer for the reaction time is started (*START TIMER:MAN.* or *AUTO*, see section 5.4.2)

- Program selection

After switching on with  the display shows the current temperature value for the thermoblock. The second display line shows the temperature programs to be selected. The control lamps above the display for the thermoblock light up green.

- Active temperature program

The display shows the current temperature value for the thermoblock. The control lamps above the display light up or flash red.

## 5 Operation

### 5.1 Inserting and removing the reaction cells



#### WARNING

Always wear protective goggles and protective clothing with long sleeves as a protection against any splashes of hot and corrosive liquids. When dealing with cell tests always follow the relevant safety data sheets and analysis specifications.



#### CAUTION

Very hot - burn hazard. Wear heat protection gloves to remove the cells when they are hot. Place hot cells in a cell rack.

1	Open the protective cover.
2	Insert or remove the reaction cells from the cell shafts without jamming.
3	Close the protection cover.





When cold reaction cells are inserted in the preheated thermoblock it can temporarily cool down by approx. 3 °C.

### 5.2 Starting a temperature program

- |   |   |
|---|---|
| 1 | Switch on the thermoreactor with  . |
|---|---|

23°C 1:148°C 2:00
----------------------

- 2 Select a temperature program with  . You can select from 8 predefined temperature programs.

23°C  
4:120°C 2:00

- 3 Start the displayed temperature program with . The control lamps for the thermoblock flash red. The nominal reaction time (in hours and minutes) appears on the display.



The reaction temperature is reached when the temperature in the thermoblock is in a range of  $\pm 1$  °C around the adjusted temperature for two minutes constantly. The control lamps of the thermoblock will then light up red.

### Operation with automatic timer

If the start of the timer for the reaction time has been set to automatic in the *SETUP* menu (*START TIMER:AUTO* see section 5.4.2), the reaction time automatically starts after the reaction temperature has been achieved. The reaction temperature is kept constant during the reaction time.

After the reaction time has expired the control lamps flash red.

The temperature program is finished.

The thermoreactor is in the program selection mode. As soon as the thermoblock has cooled down to under 50 °C, the control lamps switch themselves off.

**Operation with manual timer**

If the start of the timer for the reaction time has been set to manual in the *SETUP* menu (*START TIMER:MAN.* see section 5.4.2), an *S* is displayed in front of the nominal reaction time. With this setting the thermoreactor controls the temperature until the timer for the reaction time is started by pressing .



100°C  
52:00

- 4 Start the timer for the reaction time with . The *S* in front of the reaction time disappears.

The reaction temperature is kept constant during the reaction time. The control lamps of the thermoblock light up red.

After the reaction time has expired the control lamps flash red.

An audio signal sounds in addition.

- 5 Confirm the end of the reaction time for the thermoblock with .

The temperature program is finished.

The audio signal is finished.

The thermoreactor is in the program selection mode.

As soon as the thermoblock has cooled down to under 50 °C, the control lamps switch themselves off.

### 5.3 Stopping a temperature program

You can terminate a running program at any time.

- 1 Using (( )), terminate the running temperature program.  
The control lamps for the thermoblock flash red/green.  
The safety query *STOP?* is displayed.

A rectangular display window showing the text "54°C" on the top line and "STOP?" on the bottom line. The text is in a pixelated, monospaced font.

- 2 Using  confirm the safety query *STOP?*  
The temperature program is finished.  
The control lamps of the thermoblock will then light up green.  
or:  
Using (( )), exit *STOP?*.  
The query *STOP?* disappears from the display.  
The temperature program is continued.







While *STOP?* is displayed the temperature program goes on running. As soon as a section of the temperature program is finished (e.g. after the end of the heating period or after the end of the reaction time), the *STOP?* display is overwritten.

## 5.4 Settings

### 5.4.1 Setting the display contrast





The display contrast can be set in 10 steps.

1	Switch to the Standby mode.
2	Keep the  key depressed while pressing  to switch to the <i>SETUP</i> menu. <i>SETUP</i> and, in the second line, an editable parameter are displayed.
3	Using   , select <i>CONTRAST</i> .

```
SETUP
CONTRAST:5
```

4	Using  edit the contrast setting. The editing is marked on the display by *.
---	---

```
SETUP      *
CONTRAST:5
```





5	Using   , set the contrast from 0 to 9.
6	Using  , confirm the changes. The marking on the display (*) disappears.
7	Using  leave the <i>SETUP</i> menu. The changes are stored. The thermoreactor is switched on (operation mode: program selection).

### 5.4.2 Setting the timer for the reaction time

After the start of a temperature program the thermoblock starts heating up. Depending on the setting, the timer for the reaction time starts automatically after the reaction temperature has been reached or only after confirmation by keypressing.





With the setting *START TIMER:AUTO* the timer for the reaction time starts immediately after the reaction temperature has been reached.

With the setting *START TIMER:MAN.* the timer for the reaction time only starts after confirmation by keypressing.

1	Switch to the Standby mode.
2	Keep the  key depressed while pressing  to switch to the <i>SETUP</i> menu. <i>SETUP</i> and, in the second line, an editable parameter or a temperature program are displayed.
3	Using   , select <i>START TIMER</i> .

```

SETUP
START TIMER:MAN.
  
```

4	Set the start of the timer for the reaction time with  . The editing is marked on the display by *.
5	Using   , select <i>MAN.</i> or <i>AUTO</i> .
6	Using  , confirm the changes. The marking on the display (*) disappears.
7	Using  leave the <i>SETUP</i> menu. The changes are stored. The thermoreactor is switched on (operation mode: program selection).

## 6 Maintenance, cleaning, disposal

### 6.1 Maintenance

The thermoreactor TR 320 is maintenance free. Check the ventilation slots on the rear panel of the instrument at regular intervals. Remove any accumulations of dust in the slots, e.g. with a vacuum cleaner. Do not use compressed air!



#### CAUTION

**Fire hazard! The ventilation slots in the bottom and rear panel of the instrument must always be free. Air circulation in the area of the ventilation slots must not be impeded.**

### 6.2 Exchanging the fuses



#### CAUTION

**defective fuse may only be replaced by an original fuse with UL approval. The original fuse is listed in section 9 REPLACEMENT PARTS AND ACCESSORIES / OPTIONS.**

- |   |   |
|---|---|
| 1 | Disconnect the line power cable from the thermoreactor. |
|---|---|

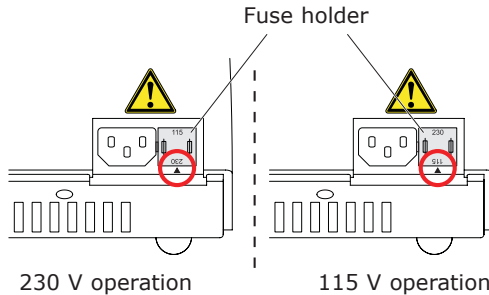

- |   |  |
|---|--|
| 2 | Pull out the fuse holder.  |
| 3 | Exchange defective fuses.  |
| 4 | Turn the fuse holder so that the arrow on the housing points to the line voltage (115 or 230 V) provided by the power supply system. |
| 5 | Push the fusion holder completely in.  |



### 6.3 Cleaning the enclosure

Wipe the thermoreactor with a damp cloth.

#### **Note**

*The housing is made of synthetic material. Thus, avoid contact with acetone or detergents that contain solvents. Remove any splashes immediately.*

### 6.4 Cleaning the thermoblocks of spilled cell contents

If liquid penetrated a thermoblock (e.g. from a leaking or broken cell), clean the thermoblock as follows:



#### **WARNING**

**Cells can contain poisonous or corrosive substances. If the content was released, heed the safety datasheet of the cell test and take the required protective measures (protective goggles, protective gloves etc.).**



#### **CAUTION**

**Danger of cuts due to broken glass. Remove any broken glass with a pair of tweezers completely. Do not pick any broken glass with your bare fingers.**



#### **CAUTION**

**Burn hazard on the hot thermoblock. Prior to cleaning, allow the thermoreactor to cool down.**

1	Switch off the thermoreactor and disconnect the power plug.
2	Allow the thermoreactor to cool down.
3	Unscrew the cover plate on top of the thermoblocks.
4	Remove any broken glass with a pair of tweezers <u>completely</u> .
5	Clean the cover plate, block surfaces and borings with a damp cloth.
6	Screw on the cover plate again.

**CAUTION**

**Fire hazard! If any flammable detergents are used, completely remove all detergent residues prior to the next commissioning.**



Discoloration that remains on the thermoblock and cover plate does not affect the functioning of the thermoreactor.

**6.5 Disposal**

Dispose of the thermoreactor as electronic waste at an appropriate collection point. It is illegal to dispose of the thermoreactor in household refuse.

## 7 What to do if...

<b>There is nothing on the display</b>	<b>Cause</b>	<b>Remedy</b>
	The power supply is interrupted	<ul style="list-style-type: none"><li>- Check power cable and connections</li><li>- Exchange the fuses</li><li>- Have repaired by service department</li></ul>
<b>Bars are displayed instead of the temperature (-°C)</b>	<b>Cause</b>	<b>Remedy</b>
	In the program selection mode: Internal temperature sensor defective	<ul style="list-style-type: none"><li>- Have repaired by service department</li></ul>
<b>Cell contents spilled / thermoblock contaminated</b>	<b>Cause</b>	<b>Remedy</b>
	e.g. leaking cell	<ul style="list-style-type: none"><li>- see section 6.4</li></ul>

## 8 Technical Data

<b>Reactor type</b>	Dry temperature control device with safety cover
<b>Cell shafts</b>	12 cell shafts for reaction cells, diameter: $16 \pm 0.2$ mm
<b>Reaction time setting</b>	20 min, 30 min, 60 min, 120 min (via fixed programs)
<b>Temperature setting</b>	100 °C, 120 °C, 148 °C, 150 °C via fixed programs
<b>Controlling accuracy</b>	$\pm 1$ °C $\pm 1$ digit
<b>Temperature stability</b>	$\pm 0.5$ K
<b>Overtemperature protection</b>	190 °C $\pm 5$ °C
<b>Heating time (with empty thermoblock) from 25 °C to</b>	100 °C approx. 5 min 120 °C approx. 7 min 148 °C approx. 10 min
<b>Temperature of the enclosure at an environmental temperature of 25 °C</b>	< 30 °C with a block temperature of 148 °C
<b>Housing materials</b>	Upper part: PC/ABS Blend Lower part: PA66 Protective cover: PC Cover plate: PBT GF30
<b>Dimensions</b>	D x W x H: 312 x 255 x 185 mm
<b>Weight</b>	3 kg

<b>Power supply</b>	115/230 VAC 50/60 Hz, allowed voltage tolerance: $\pm 15\%$ Maximum power consumption: 280 W Fuses 2 x 3.15 AT
<b>Protective class</b>	I according to DIN VDE 0700 part 1
<b>Overvoltage category</b>	II
<b>Protection</b>	IP 20 according to EN 60529
<b>Ambient temperature</b>	Storage: -25 °C to +65 °C Operation: +5 °C to +40 °C
<b>Climatic class</b>	2 according to VDI/VDE 3540 Relative humidity: Yearly mean: < 75 % 30 days /year: 95 % Other days: 85 % Light dew: yes Site altitude: max. 5000 m above sea level
<b>EMC</b>	EN 61326-1 FCC 47 CFR Part 15
<b>Test certificates</b>	cETLus, CE
<b>Safety standards</b>	EN 61010-1 EN 61010-2-010 UL 61010-1 CAN/CSA C22.2#61010-1 CAN/CSA C22.2#61010-2-010

## 9 Replacement parts and accessories / options

<b>Replacement parts</b>	<b>Designation</b>	<b>Accessory</b>
	REP3-3000 1004	Original fuse set (2 items; 3.15 A) with UL approval
	REP3-3000 1006	Original power cable, type EU
	REP3-3000 1007	Original power cable, type UK
	REP3-3000 1008	Original power cable, type USA/Canada
	REP3-3000 1009	Original power cable, type Australia

**Index****C**

Commissioning.....	10
Components of the thermoreactor ...	6
Control lamps (LEDs).....	16

**D**

Display.....	16
--------------	----

**F**

Fuses.....	24
------------	----

**K**

Keys .....	15
------------	----

**M**

Maintenance .....	24
-------------------	----

**O**

Operating and display elements ....	14
Operating modes.....	17

**P**

Program selection.....	17
------------------------	----

**S**

Safety .....	7
Scope of delivery.....	10
Setting the display contrast .....	22
Standby .....	17
Starting a temperature program....	18
Stopping a temperature program...21	

**T**

Temperature program active .....	17
Trouble shooting.....	27

**W**

What to do if... ..	27
---------------------	----



Analytical Products

We provide information and advice to our customers on application technologies and regulatory matters to the best of our knowledge and ability, but without obligation or liability. Existing laws and regulations are to be observed in all cases by our customers. This also applies in respect to any rights of third parties. Our information and advice do not relieve our customers of their own responsibility for checking the suitability of our products for the envisaged purpose.

The life science business of Merck KGaA, Darmstadt, Germany operates as MilliporeSigma in the U.S. and Canada.

Merck KGaA, Frankfurter Straße 250, 64293 Darmstadt, Germany

EMD Millipore Corporation, 400 Summit Drive, Burlington MA 01803, USA  
Sigma-Aldrich Canada Co. or Millipore (Canada) Ltd. , 2149 Winston Park,  
Dr. Oakville, Ontario, L6H 6J8

The vibrant M, Supelco, and Spectroquant are trademarks of Merck KGaA, Darmstadt, Germany or its affiliates. All other trademarks are the property of their respective owners. Detailed information on trademarks is available via publicly accessible resources.

© 2020 Merck KGaA, Darmstadt, Germany and/or its affiliates.  
All Rights Reserved.

