

User Guide

mPAGE® Mini Gel Tank and Mini Wet Transfer System

MGT-2
MGT-4
MWTS



General

Introduction	2
Specifications	2
Gel Compatibility	3
Cleaning	3
Chemical Compatibility	3
Safety	3

mPAGE® Mini Gel Tank

Introduction	4
Components	
Required Materials (not supplied)	
mPAGE® Mini Gel Tank Setup	5
Running the Gel	6

mPAGE® Mini Wet Transfer System

Introduction	7
Components	
Blotting Membrane Options	
mPAGE® Mini Wet Transfer Setup	8
Optimizing Transfer	
Replacing Parts	10
Troubleshooting	11
Electrophoresis	
Protein Transfer	
Product Ordering	15
SDS-PAGE and Transfer Systems	
SDS-PAGE and Transfer Additional Parts	
SDS-PAGE and Transfer Reagents	
Gel Caster and Kits	
Gel Casting Reagents	
Immunodetection Devices	
Power Supplies	
Staining Regents	
Transfer Membranes and Blotting Paper	
Western Blotting Detection Reagents	
Blocking, Enhancing and Stripping Reagents	
Notice	17
Standard Warranty	
Contact Information	
Technical Assistance	

Introduction

The mPAGE® Mini Gel Tank and Mini Wet Transfer system is designed for use with 8.3 cm x 10.1 cm mini gels. The mPAGE® Mini Gel Tank can be used to separate complex protein mixtures by applying an electric current to samples loaded on polyacrylamide gels, a process known as polyacrylamide gel electrophoresis (PAGE). The mPAGE® Mini Wet Transfer System facilitates the transfer of proteins from a mini acrylamide gel to a blotting membrane.

Specifications

Construction

Electrode cores	Acrylonitrile butadiene styrene (ABS), copper
Electrode core wire	99.99% platinum
Electrode core gasket	Silicone
Buffer tank and lid	Polycarbonate
Wet transfer module	Polycarbonate
Macroporous sponges	Polyurethane
Freezer pack	Food-grade refrigerant

Overall dimensions (Length x Width x Height)

Electrode core	15 cm x 5 cm x 14 cm
Tank	17 cm x 13 cm x 15.5 cm
Lid	17.3 cm x 13.5 cm x 0.21 cm
Tank and Lid	17.3 cm x 13.5 cm x 15.5 cm
Wet transfer module	16 cm x 12 cm x 18 cm

Tank Buffer Volume

Primary core (2 gels)	790 mL
Primary and secondary core (4 gels)	1265 mL
Wet transfer module with freezer pack	1255 mL
Wet transfer module without freezer pack	1405 mL

Operating and Storage Conditions

Mode	Operation	Storage & Transport
Temperature	15–25 °C	15–70 °C
Relative Humidity	20%–80%	20%–80% without condensing

Gel Compatibility

Precast gels

- mPAGE® Bis-Tris Precast Gels
- Other precast gels with cassette dimensions 8 x 10 cm (h x w)

Hand cast gels

- Gels cast with the mPAGE® Gel Caster, using mPAGE® Mini Spacer Plates and mPAGE® Mini Short Plates
- Other glass or plastic based components which form an 8 cm x 10 cm casting cassette
- Electrode core can seal cassettes with a thickness of 0.45 cm–0.48 cm

Cleaning

Use mild detergent and warm water to clean the electrode core, transfer module, and buffer tank. When cleaning the cores, use care to avoid bending or breaking the platinum wire. Do not use abrasive or strong detergents to clean the instrument. Rinse the macroporous sponges with deionized water.

Chemical Compatibility

All the components of the mPAGE® Mini Gel Tank and Mini Wet Transfer System should not be in contact with hydrochloric ethers (such as chloroform), arenes (such as methylbenzene, benzene), and acetone.

Safety

For mPAGE® Mini Gel Tank safety information, see the Safety Sheet included in the packaging. The Safety Sheet is also available on the product page at [SigmaAldrich.com](https://www.sigmaaldrich.com).



Power to the electrode cores is supplied by an external DC voltage power supply. The maximum specified operating parameters for the system are:

300 V	Maximum voltage limit
100 W	Maximum power limit
70 °C	Maximum ambient temperature



Current to the core is provided from the external power supply, entering through the lid. Current to the core is broken when the lid is removed. Do not attempt to circumvent this safety interlock; always turn off the power supply before removing the lid.

mPAGE® Mini Gel Tank

Introduction

The mPAGE® Mini Gel Tank is used to perform electrophoresis with precast or hand cast polyacrylamide gels. The one core system includes the primary electrode core and allows up to two gels to be run simultaneously. The two core system includes the primary and secondary electrode cores and allows up to four gels to be run at once.

To achieve the best performance, please read carefully and operate the instrument strictly according to this user guide.

Components

Electrode cables

Cables attached to the lid containing metal leads that allow voltage transfer from power supply to electrode core.

Tank lid

Lid with electrode cables. The lid design prevents incorrect assembly.

Primary electrode core

Contains the anode and cathode electrode connector leads; anode is marked red while the cathode is marked black. Secures up to two gels via the electrode core gasket and core clamps. Primary electrode core must be positioned in line with the lid alignment tabs.

Secondary electrode core

Contains flat electrode connectors. Anode and cathode are marked red and black, respectively. The secondary electrode core holds gel cassettes 3 and 4, and secures gels via the electrode core gasket and core clamps. Only used when running 3 or 4 gels.

Tank

Holds the electrode core(s) and running buffer. Contains alignment tabs that correctly orient the lid.

Buffer dam

Used when running an odd number of gels. (not shown)

Gel Releasers

Used to separate the glass plates when hand cast gels are used and detach the gel. (not shown)

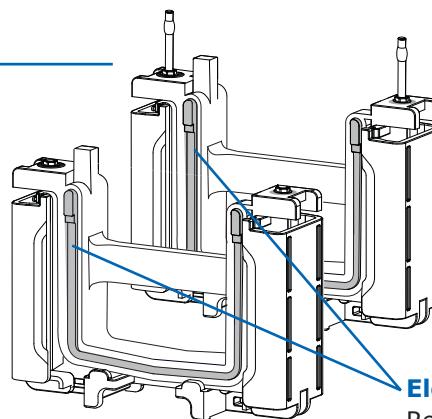
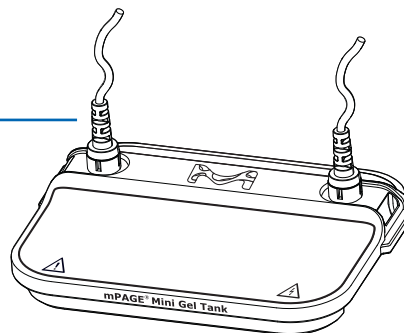

Electrode Core Gasket

Reversible silicone gasket that allows for use of multiple gel cassette types.

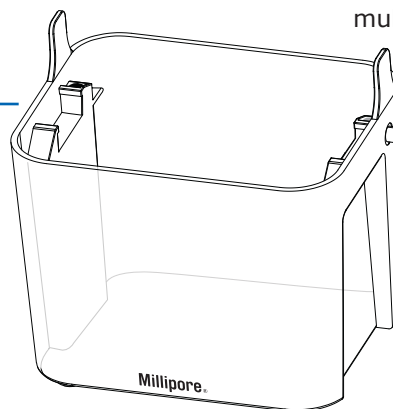

Required Materials (not supplied)

- Power Supply
- Running buffer
- Gels
- Sample loading buffer

mPAGE® Mini Gel Tank Setup

1. Ensure mPAGE® Mini Gel Tank and components are clean.
2. Adjust the electrode core gasket to the appropriate configuration for the gel type being used (remove the gasket and flip it to the desired side). Inspect electrode core gasket for damage that could prevent a proper seal. When running an uneven number of gels, the mPAGE® Buffer Dam must be used to occupy space in the electrode core, normally taken by another gel.

Electrode core gasket configurations

Hand Cast Gels or Buffer Dams

Notched side of gasket visible

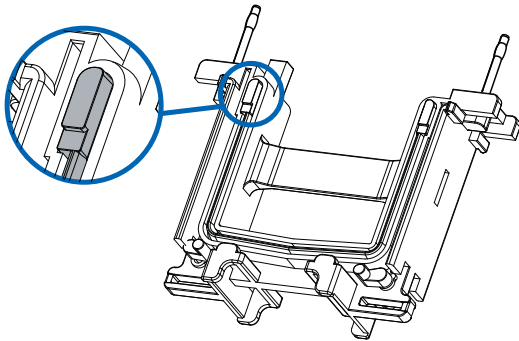

mPAGE® Precast Gels

Smooth side of gasket visible

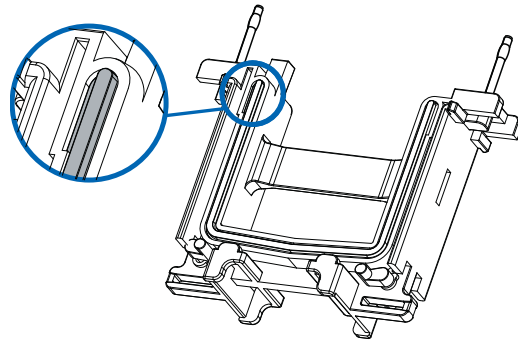

3. Open electrode core clamps by sliding clamps outward. Place the opened electrode core on a flat surface.

Note: The primary electrode core should be used alone to run 1–2 gels, do not add the secondary electrode core to the tank. The secondary electrode core should only be used when running 3–4 gels.

4. With the short plate facing toward the inside of the electrode core, place the first gel cassette behind the bottom aligners at a 30-degree angle to the top of the core. While keeping the unit balanced, place the second cassette on the other side of the electrode core. If only running one gel, use the buffer dam on the opposite side ensuring the gasket is in the notched configuration.
5. Gently push the gels toward the center, ensuring they are firmly seated against the electrode core gasket. If using the gasket in the notched configuration, ensure the top of the short plate aligns with the bottom of the notch to prevent leaks.
6. While gently compressing the gels against the core, slide the core clamps inward one at a time to secure the gels in place.
 - When using hand cast gels, verify the short plates remained under the notch of the core gasket.
 - If running more than 2 gels, repeat steps 3–6 with the secondary electrode core.

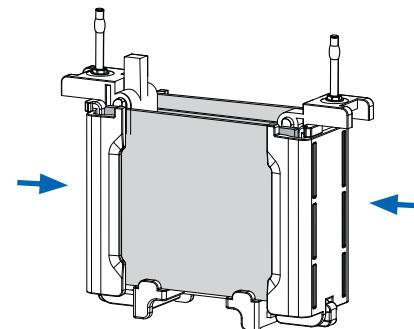
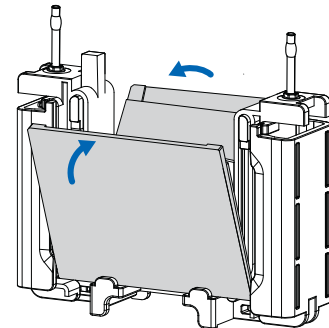
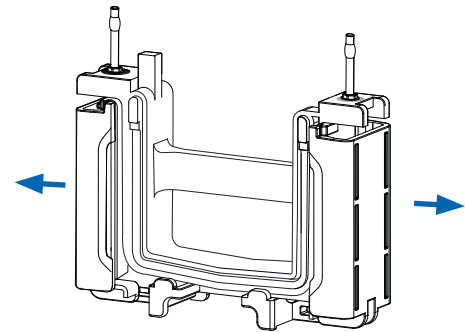

- Place buffer tank on a level surface with the fill level indications facing forward. Place the primary electrode core inside the buffer tank, positioned between the lid alignment tabs. Ensure the anode and cathode leads are on the correct sides (red on right side). The alignment tabs on the tank will guide correct lid positioning. If buffer core is installed incorrectly, inner lid tab will prevent lid sealing.

CAUTION: If lid does not close properly, check core alignment. Do not force closed.

NOTE: When running 1-2 gels, ensure empty secondary core has been removed from tank.

- If running 3-4 gels, place the secondary electrode core in front of the primary electrode core.
- Fill the electrode core(s) to just above the gel wells with running buffer. Check for leaks within the electrode core(s).
- Add additional running buffer to the electrode core(s), allowing it to spill over into the buffer tank until reaching the designated markings on the tank.
- Remove the comb and wash wells with running buffer using a transfer pipette. Alternatively, the comb can be removed and wells washed prior to installing the gels within the electrode core.
- Slowly load samples, using a gel loading tip or equivalent, allowing the solution to settle at the bottom of the well. Be sure not to exceed the maximum sample loading volume for the well configuration used.

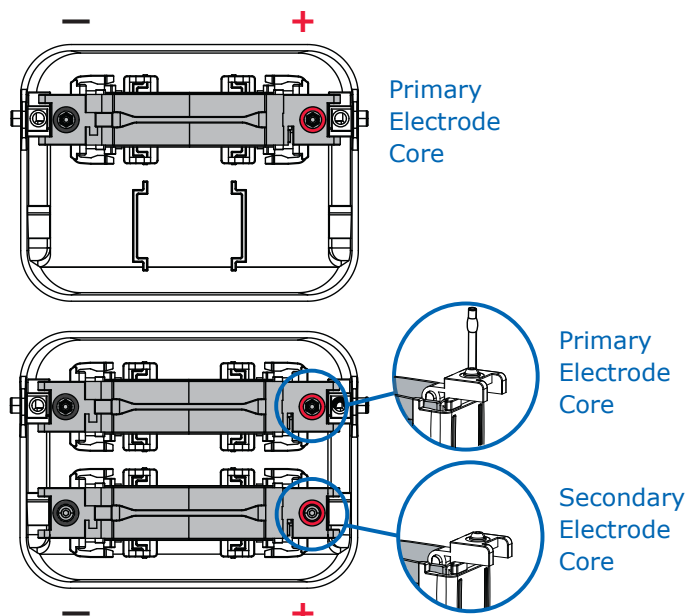

Running the Gel

- Attach the lid by positioning the alignment tabs on the tank with the corresponding slit on each side of the lid. If lid does not seat evenly, check if electrophoresis core(s) are installed in the correct orientation or position within the tank. Connect the color-coded leads to your power supply, ensure cathode and anode cables are connected correctly (red to red, black to black).
- Program and start the power supply to initiate electrophoresis. Run the gel at constant voltage until the dye front reaches ~2 mm from the bottom of the gel cassette. Run time can vary depending on the gel percentage, running buffer composition, and power supply used.
- Once electrophoresis is complete, turn off the power to the power supply and disconnect the cables.
- Remove the lid and extract electrode core(s), pour the buffer into the buffer tank.
- Open the clamps of the electrode core and remove gels.
- Rinse the electrophoresis cores and buffer tank with deionized water.

Removing the Gel

For precast gels, follow the manufacturer's recommendation for proper opening of the gel cassettes. Hand cast gels using glass plates can be opened by utilizing the plastic gel releaser. Insert the gel releaser into the gap between the well teeth and gently pry the plates apart. Hand cast gels should be scored at the spacer interface to avoid tearing.

mPAGE® Mini Wet Transfer System

Introduction

The mPAGE® Mini Wet Transfer System facilitates the transfer of proteins from a mini acrylamide gel to a blotting membrane. Wet Transfer is a powerful method that efficiently blots proteins separated by SDS-PAGE onto a nitrocellulose or PVDF blotting membrane. Once proteins are transferred to a membrane, target proteins can then be detected and visualized via immunodetection. Proteins of interest are recognized by a primary antibody, which is then recognized by a labeled secondary antibody that allows for target protein visualization.

To achieve the best performance, please read carefully and operate the instrument strictly according to this user guide.

Components

Electrode cables

Metal leads allow power transfer from power supply to the transfer module.

Tank lid

Lid with electrode cables. The lid design does not allow for incorrect attachment.

Transfer cassettes

Holds the transfer blotting sandwich. Color coded with a locking clip.

Transfer module

Used to hold the transfer cassettes. Contains the anode and cathode electrode connector leads, anode is red while the cathode is black.

Tank

Holds the transfer module and transfer buffer. Lid attaches on top.

Freezer pack

Cold pack to help prevent overheating during long transfers. Store at -20 °C. (not shown)

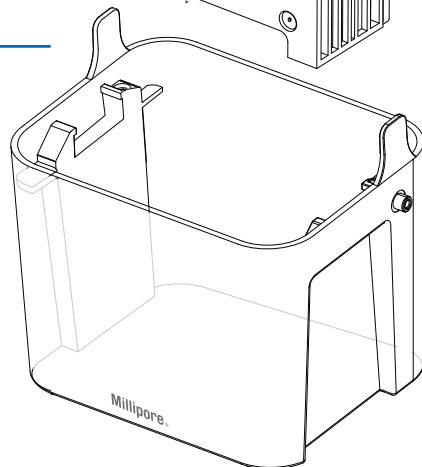
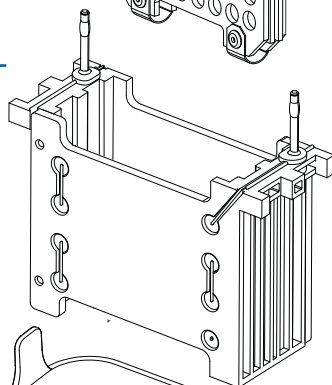
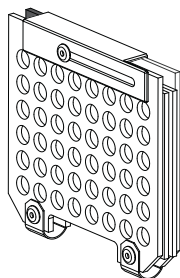
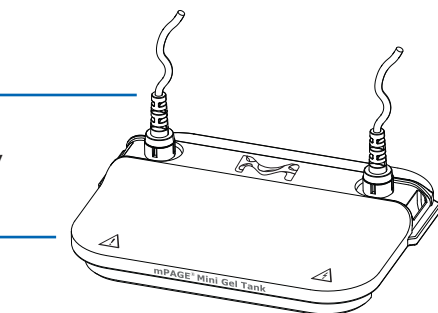

Macroporous Sponge

Fiber sponge that aids in holding the blotting sandwich tightly together.

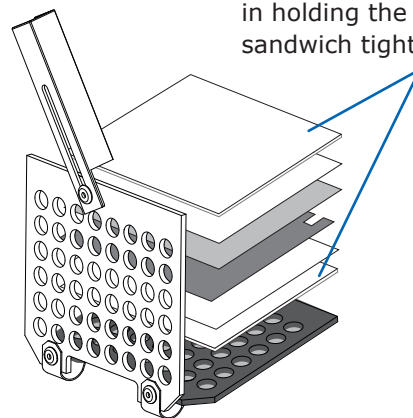

Required Materials (not supplied)

- Blotting membrane
7 cm x 8.5 cm, 1 per gel
- Filter paper
7 cm x 8.5 cm, 2 per gel
- Mini gel
- Transfer buffer, 1.5 L
- Shallow dish, large enough to fit the transfer cassette
- Additional dishes for membrane wetting/incubation and wetting macroporous sponges and filter paper
- Blot roller

Blotting Membrane Options

Immobilon®-E membrane (0.45 µm) is the only PVDF membrane that wets out in aqueous buffers, eliminating the alcohol pre-wet step. This membrane is well-suited for most Western blotting applications.

Immobilon®-P membrane (0.45 µm) is a versatile substrate that is well-suited for common immunoblotting applications.

Immobilon®-PSQ membrane (0.2 µm) is ideal for protein sequencing and immunoblotting of low molecular weight proteins. It has a higher protein binding capacity and a higher retention than 0.45 µm membranes.

Immobilon®-FL membrane (0.45 µm) was developed for fluorescence-based immunodetection. It has very low background fluorescence across a wide range of excitation and emission wavelengths.

Immobilon®-NC membrane (0.45 µm) used in common immunoblotting applications that do not require repeated blot stripping and re-probing.

mPAGE® Mini Wet Transfer Setup

1. Position the buffer tank on a level surface with the fill indications facing forward. Add the empty transfer module to the buffer tank ensuring electrode leads are on the correct sides (red to red, black to black).
2. Add 1000 mL of transfer buffer to the tank.
3. Activate or pre-wet membrane as outlined below for your membrane type.

If using PVDF blotting membranes such as Immobilon®-P, -FL or -PSQ

Activate the membrane with methanol, ethanol, or isopropyl alcohol by carefully adding the membrane to a dish containing the alcohol to avoid air locking. Rinse membranes in deionized water to remove residual solvent prior to incubating in transfer buffer. Transfer buffer composition can vary based on gel chemistry, blotting membrane and molecular weight of the protein(s) to be transferred. Most common transfer buffers contain 10–20% alcohol, and may be supplemented with 0.025–0.25% sodium dodecyl sulfate (SDS). Transfer buffer may be chilled prior to use to help with heat dispersion. Incubate blotting membranes for a minimum of 5 minutes.

If using nitrocellulose, such as Immobilon®-NC or Immobilon®-E blotting membranes

Add desired transfer buffer containing 10% methanol to an appropriately sized container and gently float membrane on the transfer buffer to avoid air locking. Incubate for a minimum of 5 minutes.

4. Assemble the blotting sandwich. Polyacrylamide gels may require pre-equilibration in transfer buffer prior to transfer to remove salts and residual SDS. Refer to manufacturers recommendation.

- a. Open the transfer cassette and place black side down – clear side up, in a vessel containing enough transfer buffer to cover the sandwich.
- b. Pre-wet sponges and filter paper in separate container(s) filled with transfer buffer.
- c. Place one macroporous sponge on the black side of the cassette.
- d. Place a sheet of pre-wetted filter paper on top of the sponge and roll out any potential air bubbles.
- e. Place the gel on top of the filter paper, wet blot roller in transfer buffer and roll out any potential air bubbles.
- f. Place the activated pre-equilibrated membrane on top of the gel and remove any air bubbles with a blot roller.
- g. Place pre-wetted filter paper on top of the membrane and roll out any air bubbles.
- h. Place macroporous sponge on top of the filter paper.
- i. Fold clear side of cassette toward black side to enclose sandwich. Being careful not to displace any blot sandwich components, engage locking clip by swinging down and sliding back until secure.

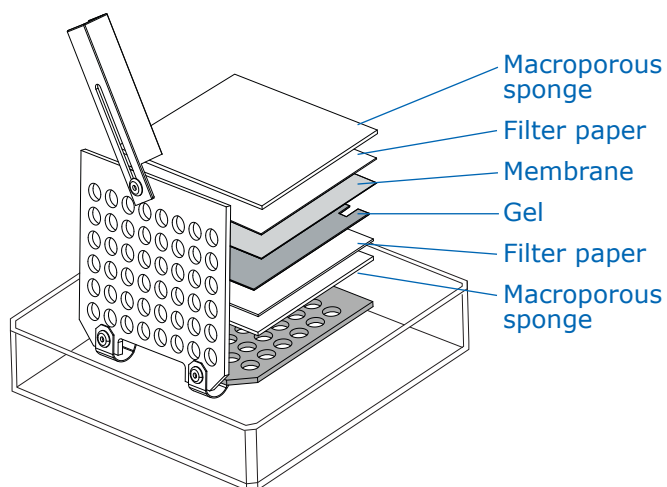

5. Place the assembled transfer cassette in the transfer module, ensuring the black cassette side faces the black side of the transfer module.
6. If transferring two gels, repeat steps 3–5.
7. Add the freezer pack and a stir bar, if desired.
8. Add additional transfer buffer until liquid level reaches the indicated blotting mark on the tank.
9. Connect the lid and attach the electrode cables to the power supply.
CAUTION: If lid will not close properly, check transfer module alignment. Do not force closed.

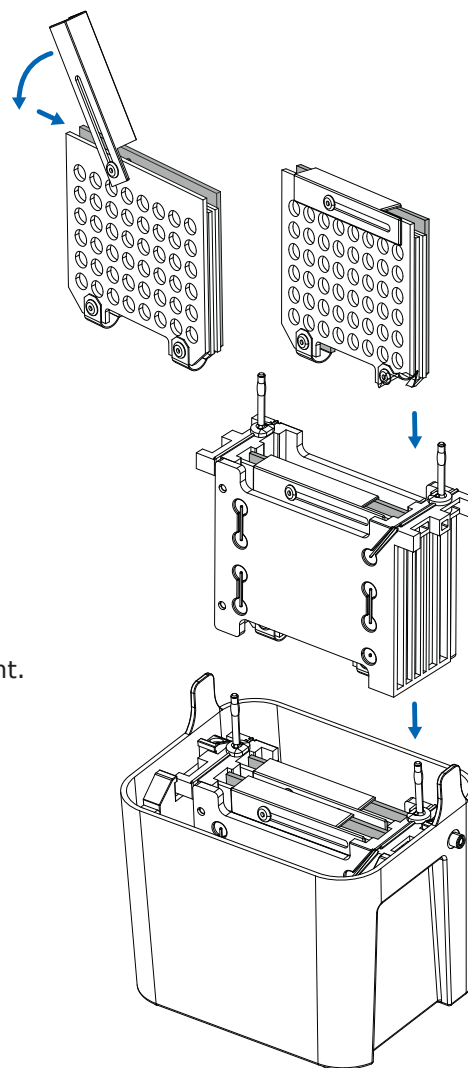

10. Typical transfer conditions are 50–100 V for 1 hour (or 30 V overnight); transfer conditions may need to be further optimized to account for differences in transfer buffer composition and gel chemistry or gel thickness.

Depending on the molecular weight of the protein of interest, further optimization of transfer time may be required.

11. Remove the membrane from the blot module and rinse in deionized water to remove transfer buffer and residual gel debris. Discard filter paper and gel.
12. Rinse the transfer components and tank with deionized water.

Optimizing Transfer

Successful protein transfer onto blotting membranes depends on several factors. Proper optimization of electrophoresis conditions such as gel chemistry, gel percentage and sample loading combined with optimization of transfer buffer composition and transfer conditions is required to enable quantitative analysis.

Membrane choice

Nitrocellulose and PVDF membranes are typically used in western blotting. There are distinct differences between the two membranes. PVDF membranes exhibit high mechanical strength and protein retention, which makes this membrane ideal when repeated stripping and re-probing is required. PVDF membrane may also provide advantages when working with high molecular weight proteins since the membrane can be used with no or low concentrations of alcohol in the transfer buffer. Nitrocellulose typically has lower mechanical strength than PVDF membrane which limits the amount of stripping and re-probing that can be performed. The alcohol required in the transfer buffer when working with nitrocellulose can result in gel shrinkage which makes it more difficult to transfer high molecular weight proteins.

Addition of sodium dodecyl sulfate (SDS) and alcohol

SDS is used to aid in the elution of high molecular weight proteins from the SDS-PAGE gel, but it may reduce the binding efficiency of proteins to the blotting membrane. The concentration of SDS has to be carefully optimized to avoid blow-thru of proteins of interest. The SDS concentration, in many cases, is balanced with the addition of alcohol to the transfer buffer. Typical SDS concentration can range from 0.025–0.25%. Alcohol concentration typically ranges from 0–20%, to successfully capture low molecular weight proteins the alcohol concentration may be increased. In recent years, methanol has been replaced by ethanol or isopropyl alcohol in the transfer buffer. Switching the type of alcohols used during transfer will require optimization as the results may vary.

Gel percentage consideration

Gel percentage and target protein size should be carefully considered to assure efficient protein transfer. The gel porosity decreases with increasing acrylamide concentration, low percentage gels are typically better suited for high molecular weight protein while high percentage gels are better suited for small molecular weight proteins. Gradient gels offer advantages when proteins with various molecular weight are to be detected.

Replacing Parts

Parts may wear out with use. The [Product Ordering on page 15](#) lists replacement parts and other supplies. Please download replacement part installation directions from the product pages at [SigmaAldrich.com](https://www.sigmaaldrich.com). If you have questions, please contact us at [SigmaAldrich.com/techservice](https://www.sigmaaldrich.com/techservice).

Troubleshooting

Problem	Cause(s)	Solution(s)	
Electrophoresis			
Smiling, center lanes run faster than outside lanes	Localized hot spot in center of the gel	Buffer not mixed well or buffer in electrode core too concentrated; remake buffer, ensuring thorough mixing, especially when diluting 5x or 10x stock	
	Excessive power (voltage) applied	Lower voltage setting from 200 V to 150 V	
Lanes vary in width	Loading volume significantly differs from lane to lane	Use similar loading volume for all samples	
	High detergent concentration	Many non-ionic detergents interfere with electrophoresis, keep SDS concentration 10x greater than the non-ionic detergent. If possible, dilute sample or remove detergent	
	Salt concentration too high		If possible, dilute sample
			Perform dialysis using Amicon® Ultra to remove salt
			Use Pur-A-Lyzer™ dialysis tubes to reduce salt concentration
	Protein aggregation	Optimize sample preparation	
	Sample allowed to diffuse in well	Start electrophoresis immediately after sample loading	
Smearing of sample, no defined bands	DNA contamination	Shear DNA prior to loading	
Visible streaks in lane, low resolution	Excessive amount of protein loaded	Reduce amount of total protein loaded	
		Increase gel thickness	
Wavy or distorted bands	Incomplete polymerization	Increase APS & TEMED concentration in the stacker	
	Old reagents used	Assure TEMED & APS are active and stored appropriately	
	Bubbles between stacking and resolving gel	Add ethanol on top of resolving gel	
	Uneven stacker resolving gel interface	Caster was not level Add ethanol on top of resolving gel	
Gel is running at an angle	Tank is not on level surface	Always make sure tank is level prior to electrophoresis	

Problem	Cause(s)	Solution(s)
Gel has stopped running, low or no current error message on power supply	Electrode core leaking	Assure that top and bottom of the electrode core clamps are in the closed position
	Damage to electrode core gasket	Inspect gasket for any damage, replace if defective
	Wrong gasket orientation	Assure that the electrode gasket is correctly oriented for the gel type being used, see page 5
Electrophoresis run taking longer than expected	Running buffer ionic strength too high	Refer to protocol and remake buffer at correct concentration
Electrophoresis run shorter than expected	Running buffer ionic strength too low	Refer to protocol and remake buffer at correct concentration
Lateral band spreading	Diffusion of the wells prior to turning on the current	Minimize the time between sample loading and turning on the power supply
	Ionic strength of the sample lower than that of the gel	Use same buffer in sample as in the gel or the stacking gel
Lanes constricted at the bottom of the gel	Ionic strength of sample higher than the surrounding gel	Desalt sample and neighboring samples
Run taking unusually long	Running buffer too dilute	Check buffer protocol and remake buffer
	Excessive salt in sample	Desalt sample
Run too fast	Running buffer concentrated	Check buffer protocol and remake buffer
	Voltage too high	Decrease voltage by 25–58%
Doublets observed where single protein species is expected (SDS-PAGE)	A portion of the protein may have been re-oxidized during the run or may not have been fully reduced prior to the run	Prepare fresh sample buffer solution if over 30 days old
		Increase concentration of reducing agent in the sample buffer
		Substitute DTT for Beta-mercaptoethanol (BME)
Fewer bands than expected and one heavy band at the dry front	Protein(s) migrating at the dye front	Increase the resolving gel total percentage concentration (%T) of acrylamide and bisacrylamide
	Protein degradation	Use protease inhibitors during sample preparation (e.g., phenylmethylsulfonyl fluoride (PMSF))
Fewer bands than expected and one heavy band at the dry front	Protein(s) migrating at the dye front	Increase the %T of the resolving gel
	Protein degradation	Use protease inhibitors (e.g., PMSF)

Problem	Cause(s)	Solution(s)
Electrode core leaks	Electrode core overfilled	Keep buffer level below the top of the spacer plate
	Improper assembly	Be sure electrode core gasket is clean, free of cuts, and lubricated with buffer
No current when using precast gel	Tape at bottom of the gel cassette was not removed	Ensure short plate is under the notch on the gasket, not on top of it
		Remove tape prior to installation into electrode core

Protein Transfer

No protein detected on blotting membrane	Incorrect orientation of the membrane in blotting sandwich	Review instructions for proper assembly of transfer stack
	PVDF membrane not activated prior to transfer	Activate PVDF membrane with 100% methanol, ethanol or IPA prior to incubation in transfer buffer
	Protein concentration too low	Increase sample loading volume or concentrate the sample
	Transfer module installed in incorrect orientation	Refer to assembly instruction for proper orientation; wrong polarity
	Insufficient transfer time	Optimize conditions by staining the gel after transfer and adding a back-up membrane to catch potential blow through during transfer
Large molecular weight proteins remain in gel	Methanol concentration too high	Decrease methanol concentration
	Gel pore size too small	Add SDS to aid in migration of larger protein out of the gel
No low molecular weight proteins detected	Protein transferred through the membrane	For best performance, protein of interest should migrate into gel 40-50%
		Decrease transfer time or voltage
		Increase alcohol concentration in transfer buffer and omit SDS
		Use a secondary back-up membrane behind the blotting membrane to catch blow through
		Use blotting membrane with lower pore size

Problem	Cause(s)	Solution(s)
Insufficient transfer	Transfer buffer pH not optimized for protein of interest	High molecular weight proteins or those with a high pI may require a transfer buffer with a higher pH such as Bjerrum and Schafer-Nielsen (pH 9.2) or Dunn carbonate transfer buffer (pH 9.9)
	Sections of blot are missing	Air bubbles not efficiently removed from blot sandwich
Protein bands are distorted	Gel overheated during transfer	Add icepack, start with cold transfer buffer, or transfer in the cold room

Product Ordering

Order online at SigmaAldrich.com.

Description	Qty	Catalogue Number
SDS-PAGE and Transfer Systems		
mPAGE® Mini Gel Tank, 2 gel	1	MGT-2
Contains:		
mPAGE® Tank	1	
mPAGE® Tank Lid with Electrode Cables	1	
mPAGE® Primary Electrode Core	1	
mPAGE® Buffer Dam	1	
mPAGE® Gel Releasers	5	
mPAGE® Mini Gel Tank, 4 gel	1	MGT-4
Contains:		
mPAGE® Tank	1	
mPAGE® Tank Lid with Electrode Cables	1	
mPAGE® Primary Electrode Core	1	
mPAGE® Secondary Electrode Core	1	
mPAGE® Buffer Dam	1	
mPAGE® Gel Releasers	5	
mPAGE® Mini Wet Transfer System	1	MWTS
Contains:		
mPAGE® Tank	1	
mPAGE® Tank Lid with Electrode Cables	1	
mPAGE® Mini Wet Transfer Module	1	
mPAGE® Mini Wet Transfer Cassette	2	
mPAGE® Macroporous Sponge	5	
mPAGE® Freezer Pack	2	
SDS-PAGE and Transfer Additional Parts		
mPAGE® Mini Wet Transfer Module	1	MWTM
mPAGE® Mini Wet Transfer Cassette	1	MWTC
mPAGE® Macroporous Sponge	5	BLSP5
mPAGE® Freezer Pack	1	FP2
mPAGE® Electrode Core Gaskets	2	ECG2
mPAGE® Electrode Core Clamp	2	ECCL2
mPAGE® Primary Electrode Core	1	ECPRIME
mPAGE® Secondary Electrode Core	1	ECSEC
mPAGE® Buffer Dam	1	BDAM1
mPAGE® Tank Lid with Electrode Cables	1	MLID1
mPAGE® Replacement Tank	1	TNK1

Description	Qty	Catalogue Number
SDS-PAGE and Transfer Reagents		
mPAGE® Color Protein Standard	500 µL	MPSTD4
mPAGE® Unstained Protein Standard	500 µL	MPSTD3
mPAGE® Western Protein Standard	250 µL	MPSTD2
MES SDS running buffer powder for mPAGE® Bis-Tris gels, each packet makes 1 L	5 pk	MPMES
MOPS SDS Running Buffer Powder for mPAGE® Bis-Tris gels, each packet makes 1 L	5 pk	MPMOPS
mPAGE® Transfer Buffer Powder, each packet makes 1 L	10	MPTRB
Gel Caster and Device Kits		
mPAGE® Gel Caster, 2pk	1	GCR2
mPAGE® Gel Casting Kit, 0.75 mm	1	MGCK-75M
mPAGE® Gel Casting Kit, 1.0 mm	1	MGCK-10M
mPAGE® Gel Casting Kit, 1.5 mm	1	MGCK-15M
Gel Casting Reagents		
TurboMix® Bis-Tris Polyacrylamide Gel Casting Kit	1 KIT	TMKIT-60
TurboMix™ Resolving Solution	216 mL	TMRES-216ML
TurboMix™ Stacking Solution	120 mL	TMSTK-120ML
Ammonium persulfate, for molecular biology, suitable for electrophoresis, ≥98%	25 G	A3678
	100 G	A3678
N,N,N',N'-Tetramethylethylenediamine (TEMED)	25 mL	T9281
	50 mL	T9281
	100 mL	T9281
Immunodetection Devices		
SNAP id® 2.0 Systems		
Mini, 7.5 cm x 8.4 cm	2	SNAP2MINI
MultiBlot, 4.5 cm x 8.4 cm	2	SNAP2MB3
Mini, 7.5 cm x 8.4 cm and MultiBlot, 4.5 cm x 8.4 cm	1 pk	SNAP2MB1

Description	Qty	Catalogue Number
Power Supplies		
Basic power supply for protein and DNA electrophoresis	US Plug	MA400-US
	Euro plug	MA400-EU
	UK plug	MA400-UK
	Japan plug	MA400-NI
	China plug	MA400-ZH
High capacity power supply for electrophoresis and Western blotting	US Plug	MA700-US
	Euro plug	MA700-EU
	UK plug	MA700-UK
	Japan plug	MA700-NI
	China plug	MA700-ZH

Staining Regents

Colorimetric

EZBlue™ Gel Staining Reagent	500 ML	G1041-500ML
	3.8 L	G1041-3.8L
Readyblue® Protein Gel Stain	1 L	RSB-1L
ProteoSilver™ Plus Silver Stain Kit	1	PROTSIL2-1KT
ProteoSilver™ Silver Stain Kit	1	PROTSIL1-1KT
Reversible Protein Detection Kit for membranes and polyacrylamide gels	1	RPROB-1KT
Ponceau S solution, 0.1% (w/v) in 5% acetic acid	1 L	P7170
Coomassie® Brilliant Blue G Solution, concentrate	1 L	B8522
Coomassie® Brilliant Blue R, pure	10 G	B7920-10G
	50 G	B7920
Fast Green FCF, die content ≥ 85%	5 G	F7252
	25 G	F7252
	100 G	F7252

Fluorescent

EZFluor™ 1-step Fluorescent Protein Gel Stain	SCT145
EZFluor™ UV 1-step Fluorescent Protein Gel Stain	SCT147
SYPRO® Orange Protein Gel Stain	S5692
SYPRO® Ruby Protein Gel Stain	S4942

Description	Qty	Catalogue Number
Transfer Membranes and Blotting Paper		
Immobilon® Blotting Filter Paper		
sheet, 7 cm x 8.4 cm	100	IBFP0785C
Immobilon®-E Blotting Sandwich		
sheet, 7 cm x 8.4 cm	20	IESN07852
Immobilon®-E PVDF Membrane		
roll, 26.5 cm x 1.875 m	1	IEVH00005
roll, 8.5 cm x 10 m	1	IEVH85R
sheet, 7 cm x 8.4 cm	4	IEVH07804
sheet, 7 cm x 8.4 cm	50	IEVH07850
Immobilon®-FL PVDF Membrane		
roll, 26.5 cm x 1.875 m	1	IPFL00005
roll, 26.5 cm x 3.75 m	1	IPFL00010
roll, 8.5 cm x 10 m	1	IPFL85R
sheet, 7 cm x 8.4 cm	10	IPFL07810
Immobilon®-P Blotting Sandwich		
sheet, 7 cm x 8.4 cm	20	IPSN07852
Immobilon®-P PVDF Membrane		
roll, 26.5 cm x 1.875 m	1	IPVH00005
roll, 26.5 cm x 3.75 m	1	IPVH00010
roll, 8.5 cm x 10 m	1	IPVH85R
sheet, 7 cm x 8.4 cm	20	IPSN07852
sheet, 7 cm x 8.4 cm	50	IPVH07850
Immobilon®-PSQ PVDF Membrane		
roll, 26.5 cm x 1.875 m	1	ISEQ00005
roll, 26.5 cm x 3.75 m	1	ISEQ00010
roll, 8.5 cm x 10 m	1	ISEQ85R
sheet, 7 cm x 8.4 cm	50	ISEQ07850
Immobilon®-NC Transfer Membrane		
roll, 33 cm x 3 m	1	HATF00010
roll, 8.5 cm x 10 m	1	HATF85R
sheets, 7 cm x 8.4 cm	50	HATF07850
Immobilon® NOW Dispenser	1	IMDISP

Western Blotting Detection Reagents

Immobilon® UltraPlus Western HRP Substrate	20 mL	WBULP-20ML
	100 mL	WBULP-100ML
Immobilon® ECL Ultra Western HRP substrate	20 mL	WBULS0100-20ML
	100 mL	WBULS0100
Immobilon® Western Chemiluminescent HRP substrate	2x 50 mL	WBKLS0100
	2x 250 mL	WBKLS0500
Immobilon® Forte Western HRP substrate	100 mL	WBLUF0100
	500 mL	WBLUF0500
Immobilon® Crescendo Western HRP substrate	100 mL	WBLUR0100
	500 mL	WBLUR0500
Immobilon® Classico Western HRP substrate	100 mL	WBLUC0100
	500 mL	WBLUC0500

Description	Qty	Catalogue Number
Blocking, Enhancing and Stripping Reagents		
Immunoblot Blocking Reagent	20 G	20-200
ChemiBLOCKER™	2x 500 mL	2170
5% Alkali-soluble Casein	225 mL	70955
Tris Buffered Saline	1 L	T5912
TWEEN® 20, for molecular biology, viscous liquid	50 mL 100 mL	P9416 P9416
Immobilon® Block-PO Reagent, Phosphoprotein Detection	100 mL	WBAVDP001-100ML
	500 mL	WBAVDP001
Immobilon® Block-FL Reagent, Fluorescent Detection	100 mL	WBAVDFL01-100ML
	500 mL	WBAVDFL01
Immobilon® Block-CH Reagent, Chemiluminescent Detection	100 mL	WBAVDCH01-100ML
	500 mL	WBAVDCH01
Western Blocker™ Solution	400 mL	W0138
Immobilon® Signal Enhancer for Immunodetection	100 mL	WBSH0500-100ML
	500 mL	WBSH0500
Blot Restore Membrane Rejuvenation Kit, 10x	1	2520-M
• Solution A, 50 mL		
• Solution B, 50 mL		
Re-Blot™ Plus Strong Antibody Stripping solution, 10X	2x 25 mL	2504
Western-Re-Probe Reagent	100 mL	WB59

Notice

We provide information and advice to our customers on application technologies and regulatory matters to the best of our knowledge and ability, but without obligation or liability. Existing laws and regulations are to be observed in all cases by our customers. This also applies in respect to any rights of third parties. Our information and advice do not relieve our customers of their own responsibility for checking the suitability of our products for the envisaged purpose.

The information in this document is subject to change without notice and should not be construed as a commitment by the manufacturing or selling entity, or an affiliate. We assume no responsibility for any errors that may appear in this document.

Standard Warranty

The applicable warranty for the products listed in this publication may be found at SigmaAldrich.com/terms.

Contact Information

For the location of the office nearest you, go to SigmaAldrich.com/offices.

Technical Assistance

Visit the tech service page on our web site at SigmaAldrich.com/techservice.

MilliporeSigma, Millipore, mPAGE, Immobilon, TurboMix, ReadyBlue, Amicon, Pur-a-lyzer, and Sigma-Aldrich are trademarks of Merck KGaA, Darmstadt, Germany or its affiliates. All other trademarks are the property of their respective owners. Detailed information on trademarks is available via publicly accessible resources.
© 2022 Merck KGaA, Darmstadt, Germany and/or its affiliates. All Rights Reserved.

The life science business of Merck KGaA, Darmstadt, Germany operates as MilliporeSigma in the U.S. and Canada.